

ROOF FITTERS: Ensure this guide is passed to your plasterer to ensure a quality install



SEE p41 FOR GUIDANCE

V6 | April 2018

LIVINROOF

INSTALLATION GUIDE

Solid roof conservatory conversion

Dear Customer,

Thank you for choosing the Ultraframe Livinroof solid replacement product. This guide is designed to make fitting as straightforward as possible. Before you commence installation of the roof, please take a moment to read the 'quick view' below then read the rest of this guide. Video links are provided for you to view on site from your smart phone.

THIS GUIDE IS WRITTEN ON THE BASIS THAT THE SURVEYOR HAS UNDERTAKEN CORRECT CHECKS FOR THE CAPABILITY / STRUCTURAL PERFORMANCE OF ANY EXISTING FRAMEWORK / WALLS / FOUNDATIONS TO VERIFY THEY ARE FIT FOR PURPOSE.

Any feedback - positive or negative - is welcomed so we can make our systems even better.

Please contact the Tech Support Team on **01200 452918** or email techsupport@ultraframe.co.uk

FITTERS:

Look out for this registration form and pass to the homeowner please



QUICK VIEW INSTALLATION SEQUENCE

STEP	PAGE	KEY INFORMATION
A Fit eaves beam, gable beam, boxgutters, Cornice lower, guttering, gable frame, gable firrings, gable wedges (Top & bottom)	A	N.B FIT THE GABLE FRAME BEFORE THE GABLE FIRTINGS
B Fit starter bars, ridge, hip or gable bars, transom bars, aluminium bolster bars, jack rafters, valley	B	
C Fit tie bars	C	N.B CHECK THE TIE BAR TYPE AND OPTIONS
D Fit struts, valley mineral wool and angle plate	D	
E Fit external flashing	E	
F Fit/glaze roof, solid panels, glass units inc. muntin bars and roof vent, glazing bar cappings, ridge bung, ridge capping & baffleseal	F	N.B THE BAFFLE SEAL IS AN ADDITIONAL PART OF THE RIDGE AND MUST BE FITTED IN ALL SITUATIONS
G Fit box gutter adaptors, complete guttering downpipes and clips, Cornice	G	
H Fit internal fascia board	H	N.B NO FASCIA CORNERS REQUIRED
I Fit 90mm insulation, valley insulation, ridge mineral wool & fill all gaps with mineral wool	I	
J If required (glazed areas) fit PVCu claddings to aluminium bolster	J	N.B THE FINISHING POINTS OF PVCu CLADDING IS CRITICAL, REFER TO LOCATION PLAN FOR SIZE & POSITION
K Fit insulated internal pelmet brackets, insulated internal pelmet frame, ridge end bracket (if required), ridge board, ridge cloaking screen (if glazed), all battens, rad end cloaking screen (if glazed), alter frame for lighting.	K	N.B IF GLAZING AREA, FIT POLYCARB CLOAKING SCREEN CLIPS TO FASCIA, SUPPORT CLIP TO SCREEN IF BOLSTERED FIT CLOSURE TRIMS BETWEEN BRACKETS' THEN FIT POLYCARBONATE CLOAKING SCREEN. DUE TO THE NATURE OF THE 'SANDWICH' CONSTRUCTION, THE CORRECTLY RATED WIRING/LIGHT FITTINGS MUST BE USED.
L Fit 25mm insulation (screws & washers), foil tape joints. Fit mineral wool into insulated internal pelmet frame	L	
M Fit plasterboard (12.5mm foil - backed) to 1. insulated internal pelmet bottom, 2. Ridge board, 3. Ceiling pitch, 4. insulated internal pelmet vertical	M	N.B INSTALL IN SEQUENCE ORDER, USE 12.5MM FOIL BACKED PLASTERBOARD

The core of the guide shows how to install a typical Georgian 4x4 roof with Jack Rafters and fitted with solid panels and glazing.

The insulated internal pelmet can be fitted in two positions, A&B.
This guide is mainly based on details A

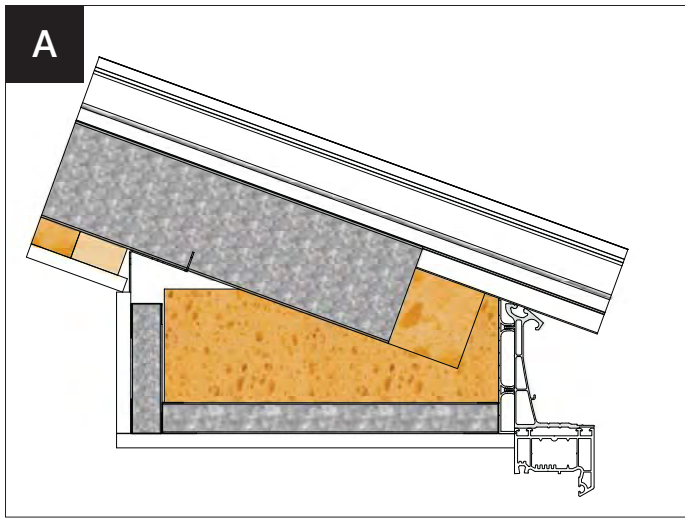

Ladder framework terminates on Fascia - standard eaves

Here we have the ladder steelwork terminating on the PFTB plank fascia (using standard eaves beam).

This detail is used when there are window frames around the complete perimeter and where there are no box gutters included in the design.

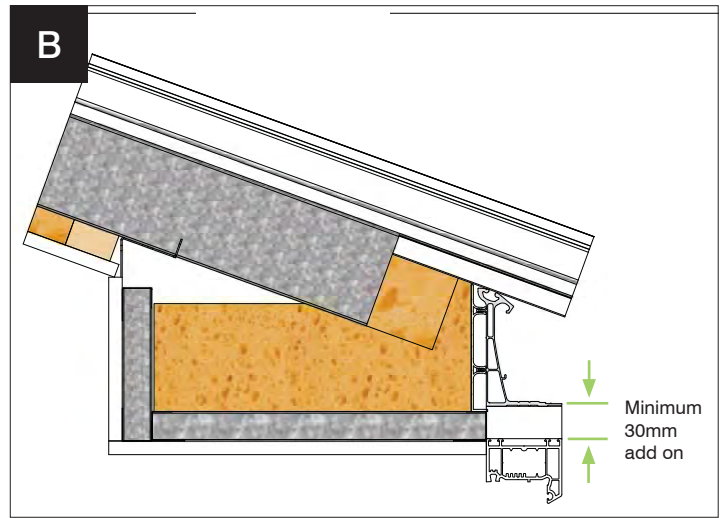

Ladder framework terminates below Fascia - standard eaves

This detail is used when there is a box gutter included in the design. The steelwork ladder terminates underneath the PFTB plank fascia.

Please note the following;
 - window frames all round, a frame add-on of at least 30mm must be used.

ALWAYS SAFELY DISMANTLE THE EXISTING ROOF AND DISPOSE OF THE OLD MATERIALS IN A SUSTAINABLE WAY

TOOLS REQUIRED

Eaves to frame fixings, host wall fixings and ridge top cap flashing trim screw not supplied.



8, 10, 13mm Socket Spanner



Deadblow Hammer or White Rubber Mallet



No. 2 Pozidrive Bit



5mm Wide Flat Blade Screwdriver



Hack Saw



Drill/Screwdriver



Long nose pliers



Gasket Shears/ Snips



4.5mm Drill Bit
10mm Drill Bit



Sealant Gun



2 x 5mm Allen Keys (Vic fixing kit)



17mm Open Ended Spanner - Tie Bars

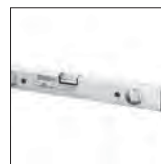

Spirit Level (magnetic useful for internals)



Tape Measure



Anglefinder



Plumb bob



Adjustable Support Prop

**MATERIALS YOU NEED TO SUPPLY:
 12.5MM FOIL BACKED PLASTERBOARD & 50mm DRYWALL SCREWS, GYPROC ANGLE BEAD RESIN ANCHORS.**

PRE-INSTALLATION CHECKS

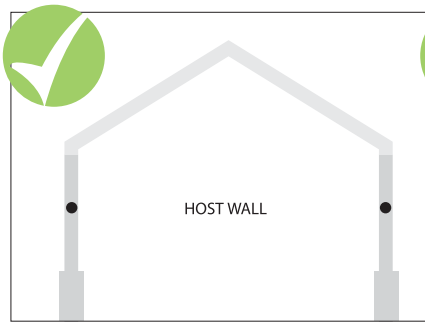

If fitting new frames do not fix the frames down - pin only to the house wall (one fix per side) to allow the conservatory to 'float'.

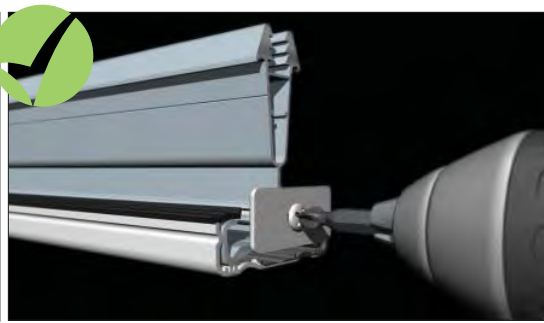

Attach the glazing bar end cap fixing blocks - as access restrictions (box gutter situations) may prevent easy attachment later. NOTE: These are attached to the end caps when despatched from the factory.

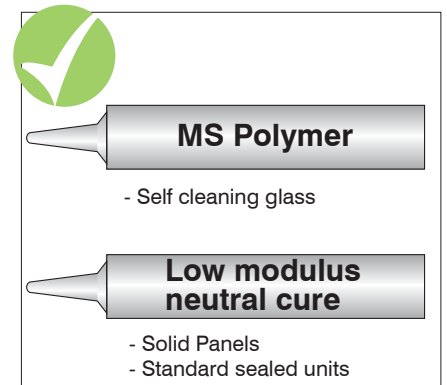

Use the correct sealant on glazing

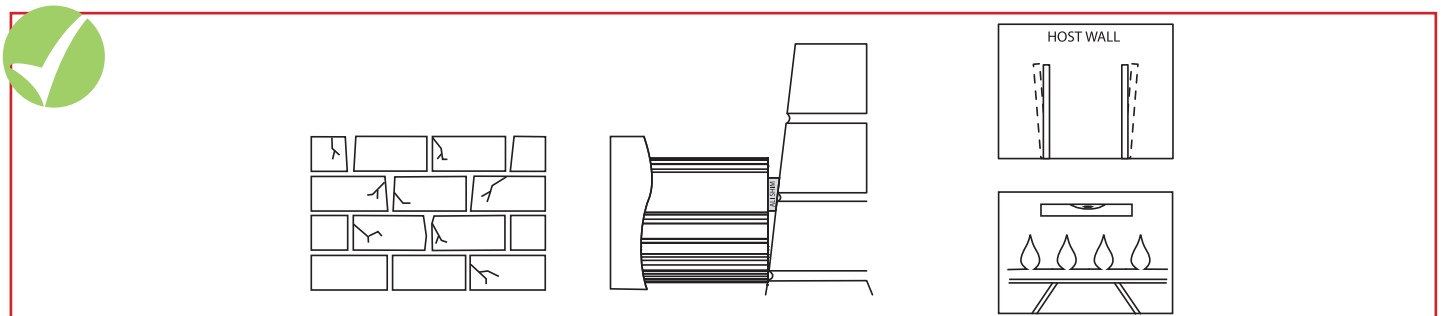

Check the condition of the host wall as this may affect the quality of the final installation. Check the host wall is plumb - any running in/or out should have been accounted for by the surveyor. If not, the ridge and starter bars may require packing out with aluminium shims. Correct alignment in this area is

critical to a successful installation - Plumb frames/level ridge. Only use the specified fixings - never be tempted to substitute alternative sizes/gauges.

General points

Care should be taken when handling components that are seen by the homeowner, as surfaces may be scratched if not handled with care. Choose a suitable area for unpacking the components and always check them before fitting. Any claims for missing or damaged parts are only accepted in line with our standard terms and conditions of sale.

Health & safety

Site safety is paramount. The Construction (Design & Management) Regulations 2015 apply to the whole construction process, on all construction projects from concept through to completion. Compliance is required to ensure construction projects are carried out in a way that secures health and safety. The installation company shall be responsible for the safety of all of the fitting team, the customer and members of the public.

The Surveyor should have carried out a risk assessment to reduce risk on site and this should have been discussed with you prior to starting.

Please use safe working platforms and ladders that comply with BS EN 131. Always use equipment in line with manufacturers recommendations. Personal Protective Equipment - such as goggles, mask and ear defenders - should be used when, for example, grinding out for the flashing.

Careful consideration should be given to the safe disposal of all packaging - Ultraframe packaging is predominantly made from recycled materials and can be readily recycled.

Product

The roof kit is supplied with a location plan, a quality control check list for the box in which this guide arrives and, of course, this installation guide. The location plan is used to match individual components to their respective position on the roof. Our numbering convention always starts at the top left, against the house wall as you look from outside the conservatory back at the host wall.

The majority of aluminium and PVCu components contain identification codes, usually by inkjetting or labelling - should you need to re-order a part this should help.

Sealing

It is important to use the correct sealant when sealing the roof.

1. For the solid panels a low modulus neutral cure brand of silicone must be used
2. For the individual 'self cleaning' glass panels use MS Polymer sealant such as Rotabond 2000.

The Superstructure

Check the Dwarf wall or Plinth for being level all round. Ensure that all frames which abut the host wall are vertically plumb, which will then allow perfect alignment with the Classic eavesbeam. Before starting to install the roof, please check the condition of the host wall and whether it's plumb - depending upon what you find, these conditions can seriously affect the final integrity of the roof.

Technical Support

Tel: 01200 452918

Email: techsupport@ultraframe.co.uk

HANDLING ALUMINIUM PRODUCTS

PAINTED ALUMINIUM PRODUCTS - PLEASE NOTE

All paints will 'chalk' to some extent and there will be a reduction in gloss level over time. (See Cleaning and Maintenance guidelines p42)

QUALITY EXPECTATIONS ON INSTALLATION.

Appearance: This is assessed based on the selection of the 'significant' (primary) surface. From a distance of 3m, stand at an oblique angle of 60degree and then defects such as blisters, runs, pin holes etc should NOT be seen.
Colour and gloss: Viewed from 5m, the coating must be of even colour and gloss with good coverage.



If storing in warehouse racking or on frails/roof racks, take care to support the products and do not over tension straps and ropes. When opening sealed packs, use a special box knife opener.

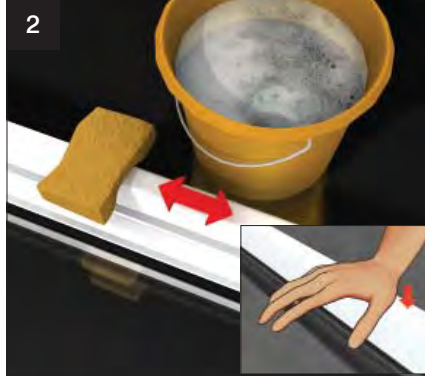

Grease marks, dirt and mastic spillage may be removed using soapy water. Take care when fitting aluminium products to not use excessive force.

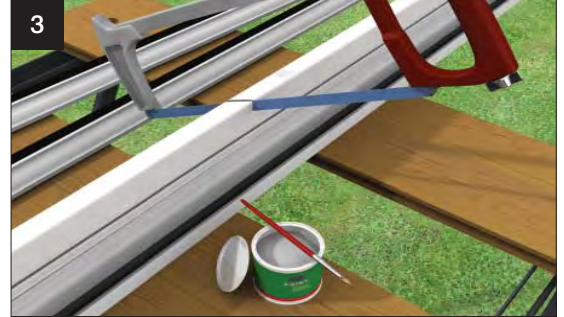

If site cutting is necessary (drainage slots need inserting or a down pipe hole has to be cut) ensure all swarf is kept away from the painted surface and then seal with a primer/corrosion inhibitor and then top coat. Alternatively, use a suitable gap sealant to prevent the onset of corrosion. These steps are critical in marine environments.

CAUTION- WHEN HANDLING ALUMINIUM FACED SANDWICH PANELS - USE PROTECTIVE HAND WEAR.

SPEEDLOCK REMOVAL



If you need to remove a glazing bar from the speedlock 2 socket assembly, remove the speedlock hood (if fitted) and release and lift the bar at the eaves end.



Gently lever up the upper deadlock.



Insert the 5mm wide flat blade screwdriver and gently push against the upper edge of the roller cam (marked yellow).



Gently pulling the bar away will automatically release the head of the speedlock.

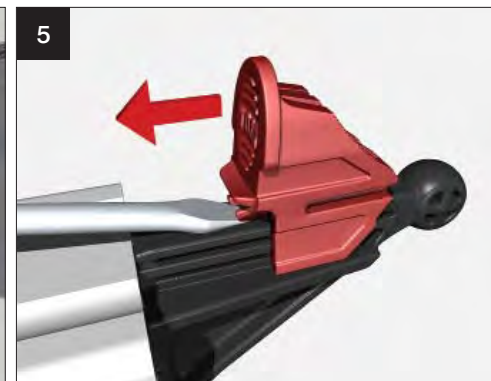

Turn the whole bar over, then insert the screwdriver blade under the lower wedge lock. Lift to allow the wedge to ride back over the serrations to its original position.

PRODUCT OVERVIEW

Glazing Bar Suite

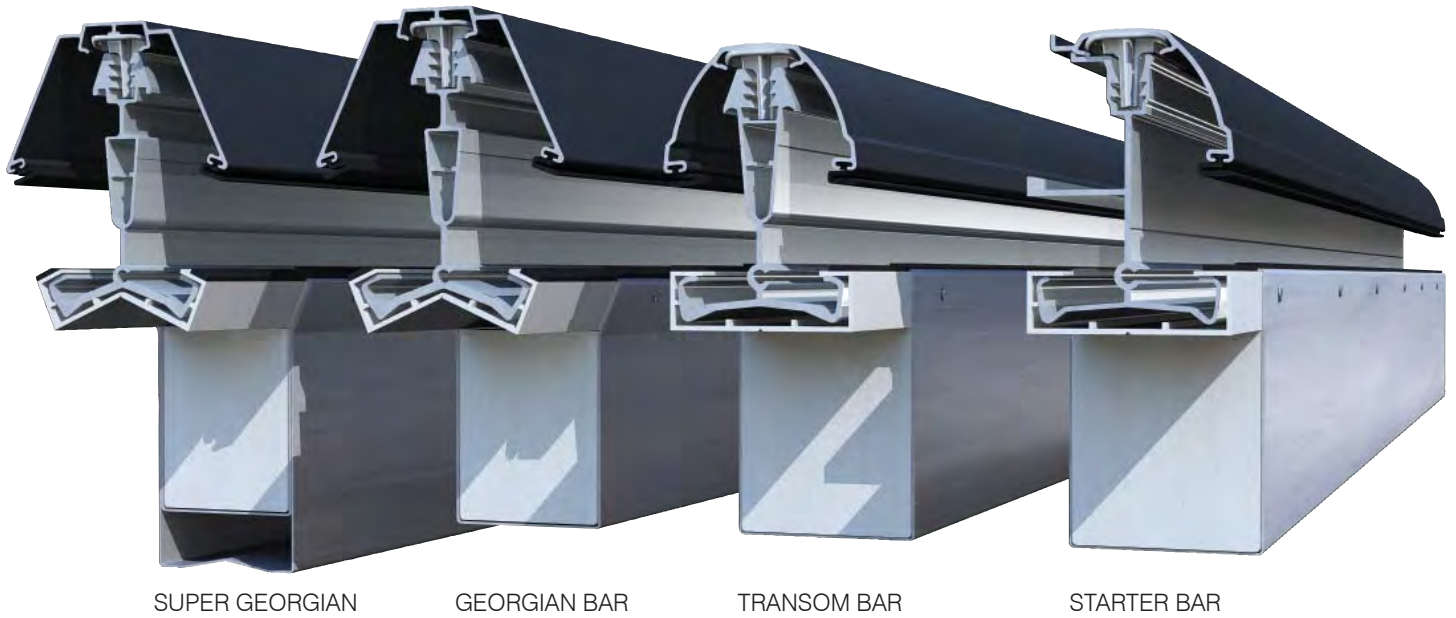

Strut (fitted to every bar on every roof)

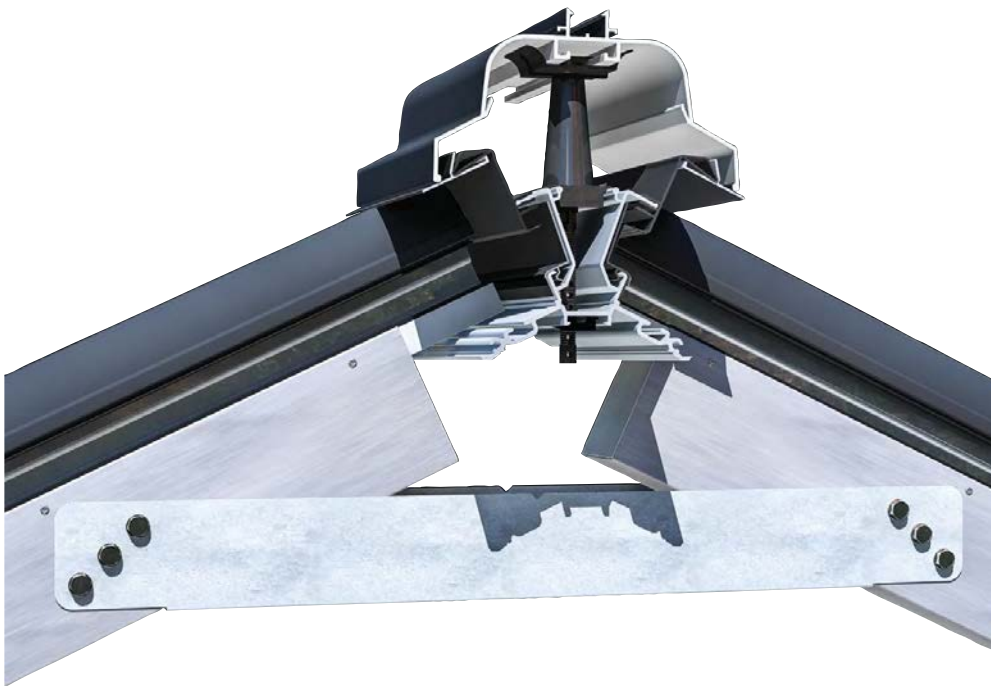

PRODUCT OVERVIEW

THESE ITEMS ARE SPECIFIED ON THE RELEVANT DESIGN



STRUCTURAL MOULDING EAVES/HOST WALL: Where the eaves beam sits against the host masonry wall, it has a structural moulding attached to the eaves beam. This has three fixing positions cast into it to allow attachment into masonry – choose the hole that directly lines up with solid masonry and attach using one resin anchor suitable for substrate / loads (other anchor types may be suitable).



SUPER DUTY EAVES BRACKET:

Where the Super Duty Eaves beam has been specified, bracket SEWC002 (left and right handed) will be supplied. This should be fitted to the eaves beam using X3 M5 X 12 taptite screws (supplied). This should then be fitted to the host wall using a minimum of 4 fixings suitable for the substrate (not supplied).

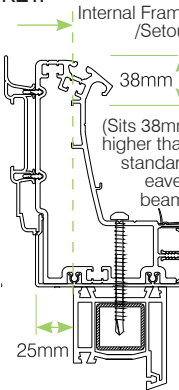

RIDGE HANGER / COMPRESSION PLATE: The ridge hanger/compression plate is attached to the host wall. Using two resin anchor bolts (not supplied).

THESE ITEMS ARE SPECIFIED AUTOMATICALLY ON SOME PROJECTS (IF STRUCTURALLY REQUIRED)

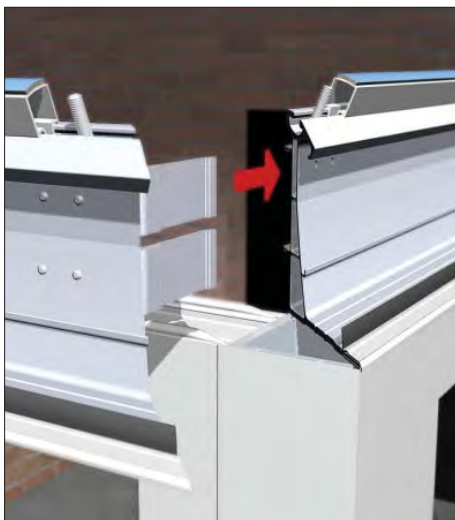

Each eaves corner (90°, 135° and 150°) is supplied pre-fitted with an additional standard cleats (2 in total).

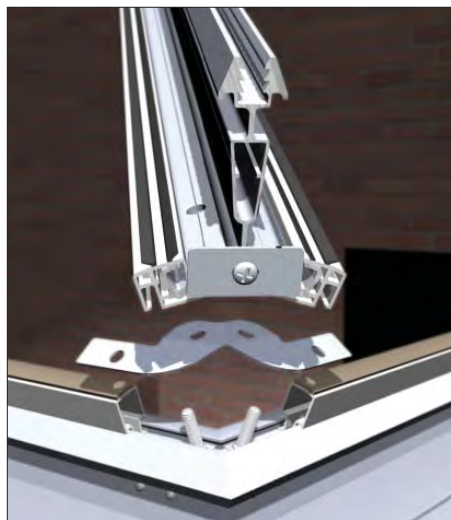

On Georgian hip bar, a butterfly cleat is laid over two captivated roofing bolts.

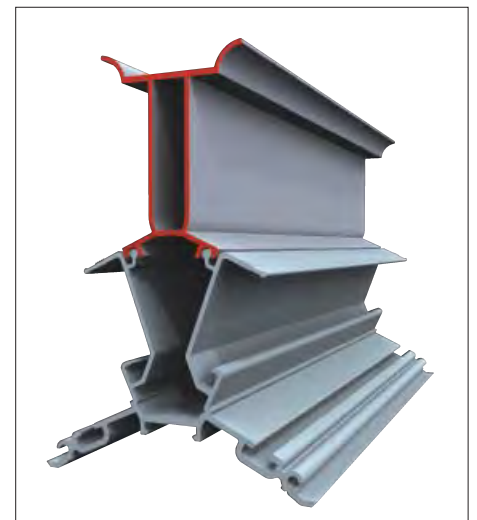

An aluminium bolster beam is factory stitched and extends along the entire length of the ridge and acts as one with the existing aluminium ridge body to virtually eliminate deflection.

SYSTEM OVERVIEW

Transom Bar - solid/glass - on fascia



Transom Bar - solid/glass - below fascia



SYSTEM OVERVIEW

Box Gutter - solid/glass - below fascia



Box Gutter - solid/solid - below fascia



SYSTEM OVERVIEW

Valley - solid/solid

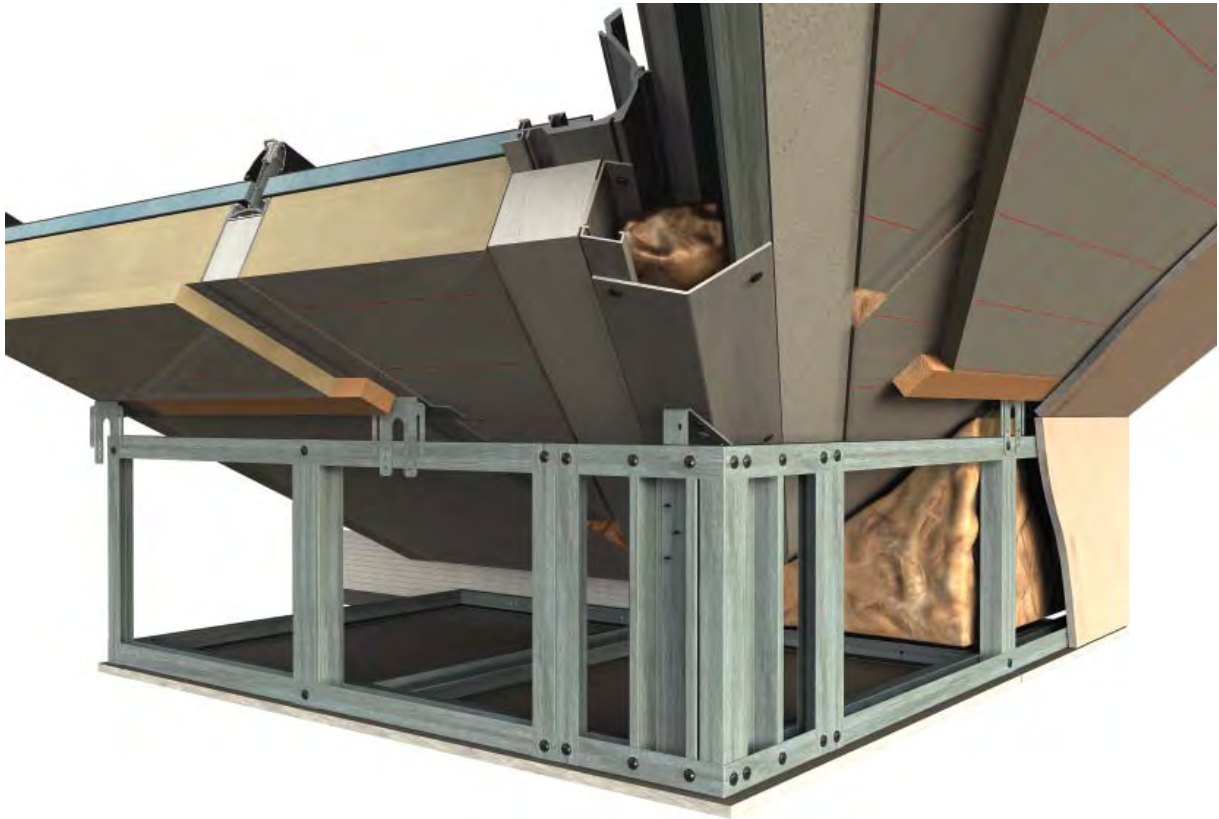

Hip - solid/solid

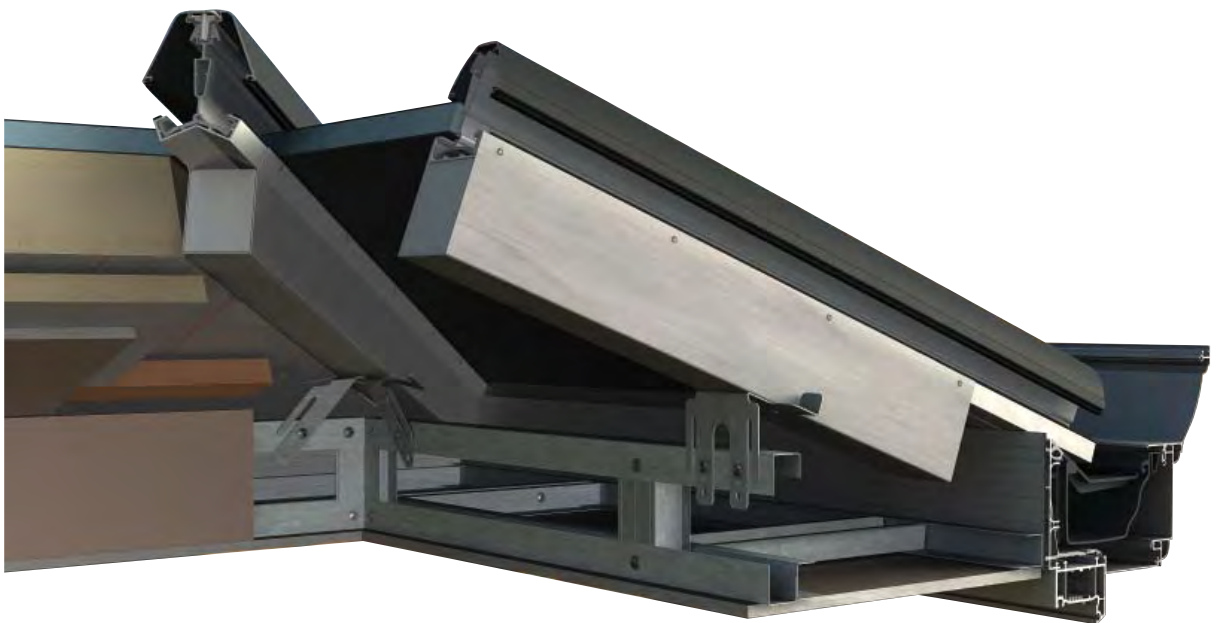

SYSTEM OVERVIEW

Gable - glass

PLEASE DO NOT ORDER / MANUFACTURE GABLE FRAMES BEFORE DISCUSSION WITH ULTRAFRAME TECHNICAL SUPPORT ON 01200 452918.

Gable frame sizes on Livinroof roofs are different to regular glazed Classic Roofs.

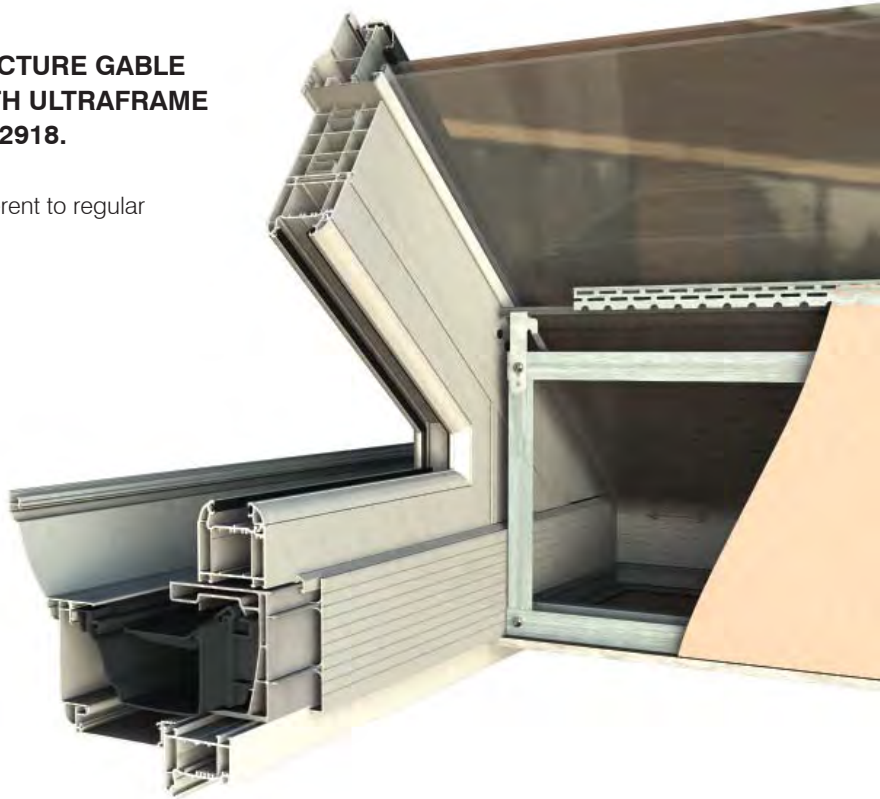

Gable - solid

PLEASE DO NOT ORDER / MANUFACTURE GABLE FRAMES BEFORE DISCUSSION WITH ULTRAFRAME TECHNICAL SUPPORT ON 01200 452918.

Gable frame sizes on Livinroof roofs are different to regular glazed Classic Roofs.

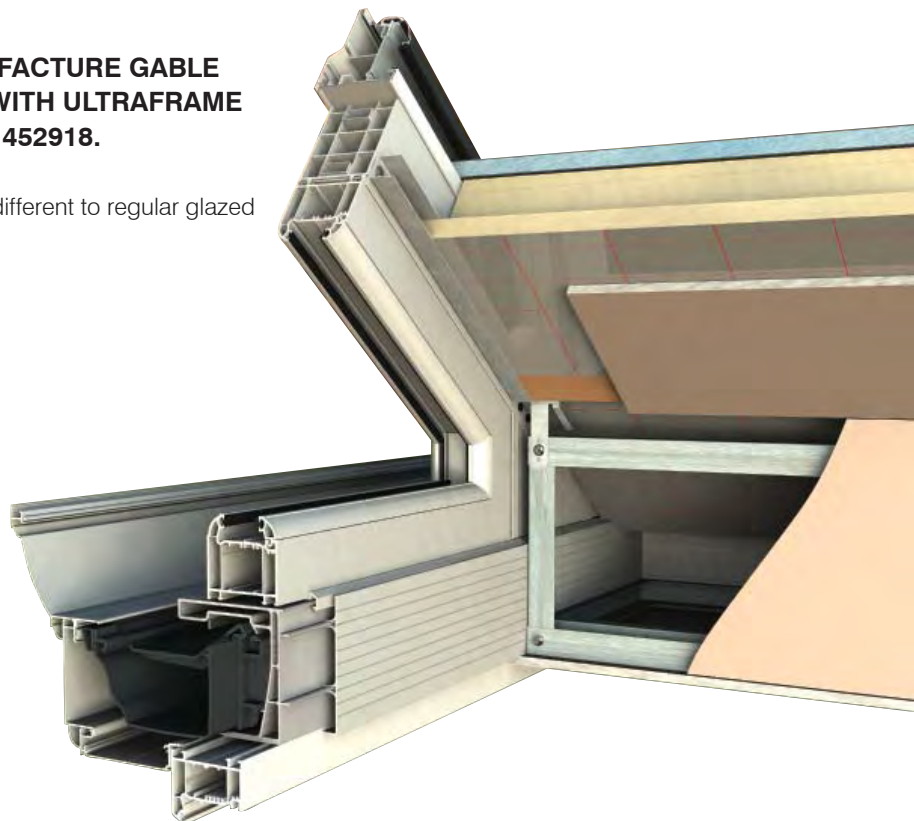

COMPONENT PARTS LIST - ADDITIONAL TO STANDARD GLAZED ROOF

 <p>LVLS001 Strut - standard</p>	 <p>LVLS002 Strut - bolster</p>	 <p>LVTS001 Strut - low ceiling</p>	 <p>LVRC001 Radius end bracket</p>
 <p>SEWC002 L/R Super Duty Structural eaves beam - wall bracket LH/RH</p>	 <p>LVPV300 Valley plate</p>	 <p>LVRB600 MGR/1 Baffle seal</p>	 <p>LVCC001 Top capping clip</p>
 <p>LVAR250 BL Multi board black</p>	 <p>LVGS001 Double sided tape</p>	 <p>LVFT045 Foil sealing tape</p>	 <p>CHAA300GR/4 PVC plasterboard trim</p>
 <p>Tie beam attachment kit</p>	 <p>LVTD600 MW/1 Tie beam</p>	 <p>LVIR001 Mineral wool insulation 2x12m x 190mm rolls</p>	 <p>LVIK025 3.5 x 50mm insulation fixing screw & washer. Provided to secure 25mm insulation board.</p>
 <p>Gable ridge wedge infill</p>	 <p>Gable eaves wedge infill</p>	 <p>LVBG240 Timber baton</p>	

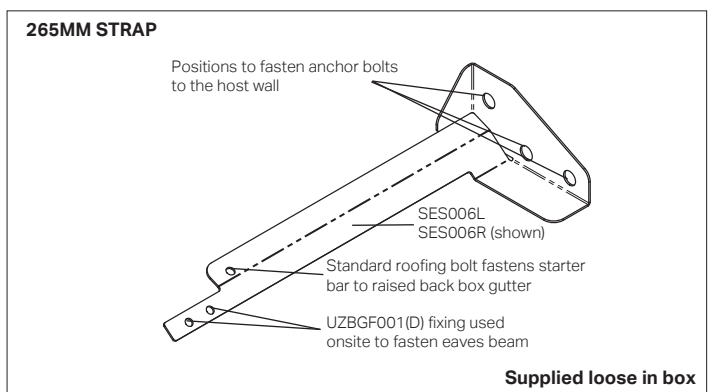
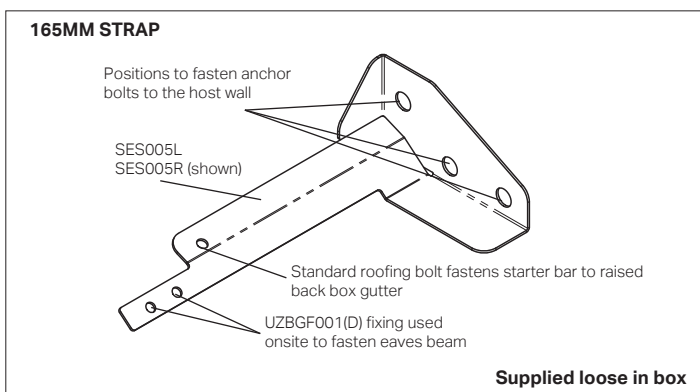

INSTALLATION

IF YOUR DESIGN FEATURES GABLE FRAMES SEE p69 - 77

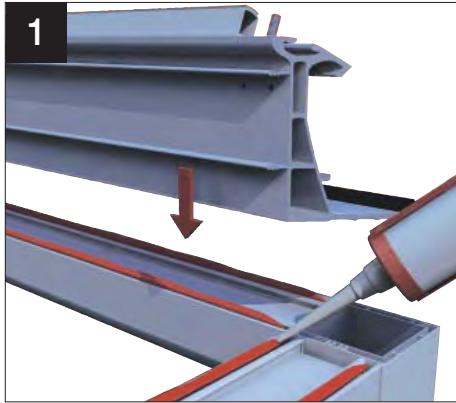

Apply a continuous bead of silicone to the front and rear inner legs of the window frames. Scale over the holes left by any old fixings. Fit the initial piece of eaves beam ensuring that the inside face of the eaves beam is flush with the inside face of the window frame.

IF A BOXGUTTER IS TO BE FITTED, IT IS STRONGLY RECOMMENDED THAT A 30MM FRAME ADD ON IS USED AT THIS STAGE.

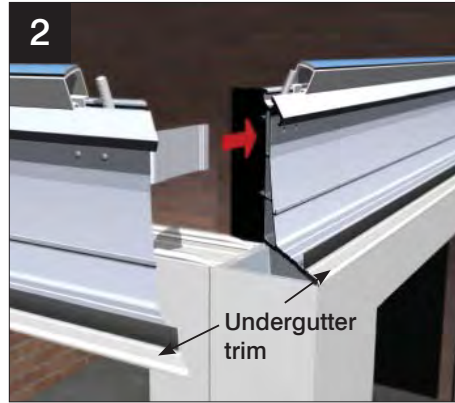

Place the next section of eaves beam into position, by slotting the corner cleat on the adjacent piece of eaves beam into the first piece.



Using the pre-drilled pilot holes, drill two 4.5mm holes through the corner cleats.

ON SOME PROJECTS A DOUBLE CLEAT IS SUPPLIED & A FURTHER BUTTERFLY CLEAT (SEE P8)

N.B. ENSURE THE UNDER GUTTER TRIM IS FITTED TO THE EAVES BEAM AND ALL THE BOLTS ARE IN SITU PRIOR TO FIXING TO THE FRAMES.

IF CORNICE IS BEING FITTED REMOVE UNDER GUTTER TRIM



Securely fit the two M5 x 12mm tap-tite screws.



Where the eaves beam sits against the host masonry wall, it has a structural moulding attached to the eaves beam. This has three fixing positions cast into it to allow attachment into masonry – **choose the hole that directly lines up with solid masonry and drill a hole into the host wall. As specified by the fixing manufacturer attach the structural moulding using a resin anchor suitable for loading/substrate (not supplied).** Silicone seal the gap where the moulding attaches to the eaves beam.



SECURELY FIT THE EAVES BEAM TO THE FRAMES USING ONE OF THE FOLLOWING 3 METHODS:

Use 38mm X 4.8mm screws (not supplied) in the position shown. Fix down at 450 centres and within 200mm of each corner. For 60mm frames use the inner eaves extrusion line and outer line of 70mm frames.

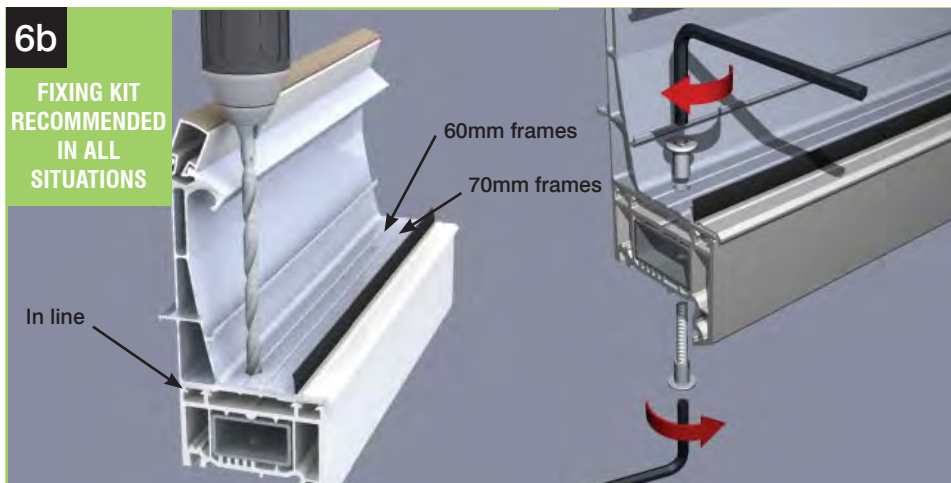

When using the Victorian Fixing Kit drill a 10mm hole through the base of the eaves beam and completely through the head of the window frame. Ensure that both sides of the 10mm hole are accessible for Allen key fixing. Use a 5mm Allen Key to tighten the fixings. The eaves beam should be fixed at 450mm centres and within 200mm of each corner. **THIS IS ULTRAFRAME'S RECOMMENDED FIXING METHOD**



Behind the head of the screw, use a 20mm washer so that the thread is biting into the aluminium eaves beam.

NOTE: Trim back any screw points protruding through the eaves beam to make flush.

INSTALLATION



Once the eaves beam is secure, run a bead of silicone down the joint where the eaves beam sections meet and where the eaves abuts the host wall. **YOU MAY AT THIS STAGE INSTALL THE GUTTERING PRIOR TO FITTING THE GLAZING BARS - If fitting Cornice fit the base of the Cornice to the eaves beam before the guttering.**

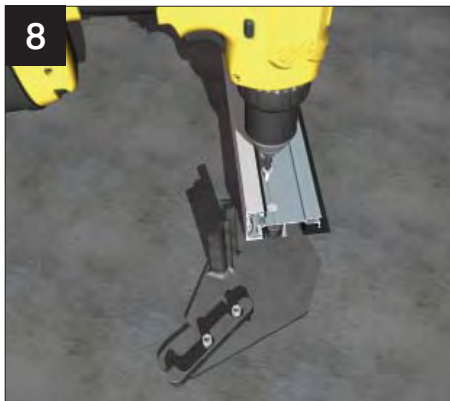

Now take the ridge hanger/compression plate assembly. On the ground, away from the conservatory, offer up the first starter bar with the soaker trim pre-fitted. Fasten using the set screws provided – do not over tighten.



Take the second starter bar and similarly offer this onto the ridge hanger/compression plate assembly. Lift the whole “A” frame assembly and get ready to install it in its final position.

N.B. IF USING LOW PITCH FIRING ON GABLE FRAME (BELOW 11°), THE FIRING MUST BE FITTED BEFORE THE CORNICE BASE OR GUTTERING

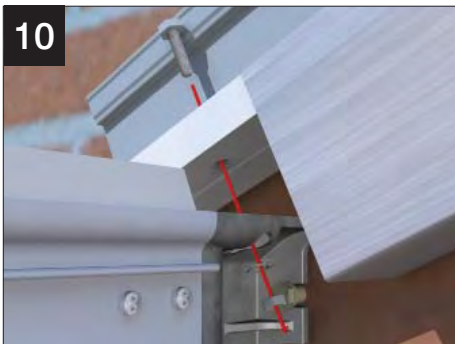

Attach the starter bar using the nut, bolt and spring washer (included in the kit) to the eaves structural moulding. Finger tighten the nut to temporarily allow the assembly to hang.



To set the ridge, use an “angle fix” to check the starter bars are at the correct pitch. Chalk/pencil a line on to the wall to mark the pitch line.



Bolt the ridge hanger/compression plate to the host wall. **Drill the plate as required to line up with solid masonry using the two resin anchors suitable for loadings/substrate. If necessary, use aluminium shims to pack out behind the plate. Check the plate is vertical and securely fastened.**



Support ridge body. Loosen the “crocodile jaw” bolts on the underside of the main ridge body – ensure it is supported at the front whilst it is gently guided onto the top half of the ‘crocodile jaw’.

Note: The starter bar is NOT attached (bolted) to the ridge body.

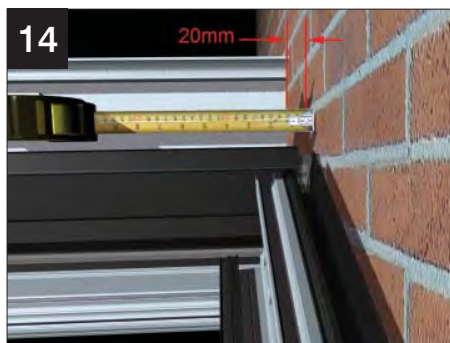

The ridge body should ideally sit 20mm back from the house wall (or 12mm from the front plate), this allows the compression plate to evenly distribute ridge loads into the host wall (max tolerance 50mm). **If the host wall is out of plumb, pack out behind the starter bars and use the longer bolts provided. This ensures the starter bars are at 90° to ridge body (and not tapering).**

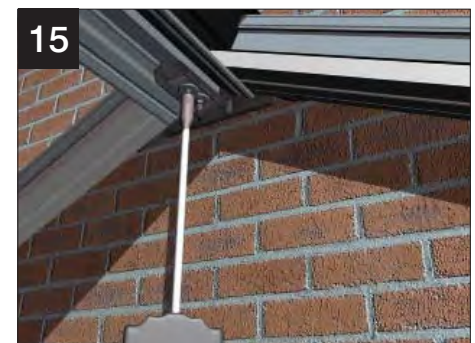

Ensure that the fixing on the eaves moulding and the nuts on the ‘crocodile hanger’ are tightened up.

Also ensure the bolts at the top of the starter bar, are tightened up.

INSTALLATION



Continue to support the ridge and offer up the transom glazing bars (above), loosely attaching using the roofing nuts and bolts supplied. Ensure the rain baffle upper leg is lifted prior to placing the glazing bars.



Offer up the hip bars.



Using Speedlock 2 on the glazing bar end, offer the 'ball' into the matching socket.

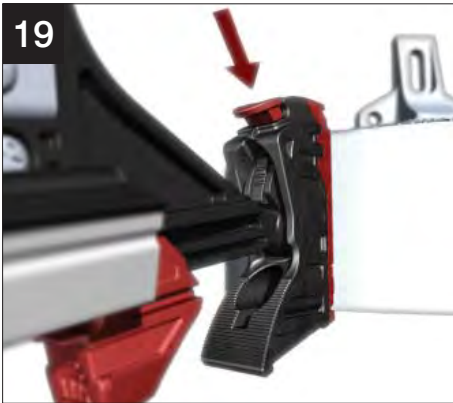

Attach bar at eaves position. Using your thumb push down the upper dead lock so it's flush. **YOU MUST NOT PUSH UP THE LOWER WEDGE LOCK UNTIL STEP 36.** To remove the bar, lever up the dead lock using a flat blade screwdriver, then insert the screwdriver to release the socket latch.



Next, attach the speedlock hood over each bar, sliding it under the co-extruded gasket of the glazing bar undercladding.



Push down to locate, with the final position abutting the front edge of the die cast end.

IF YOU NEED TO REMOVE A Speedlock, SEE P6

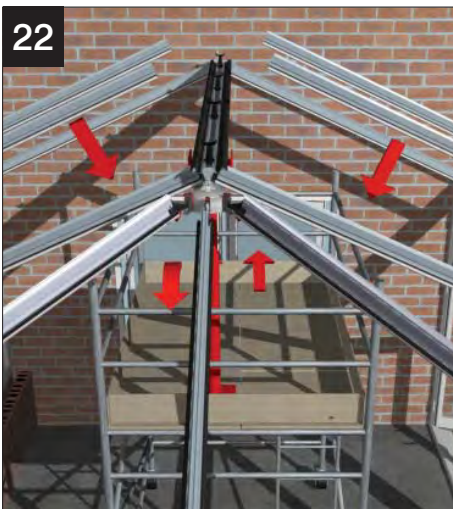

Continue to attach all the glazing bars using the location plan provided to check each bars final position with its corresponding label.

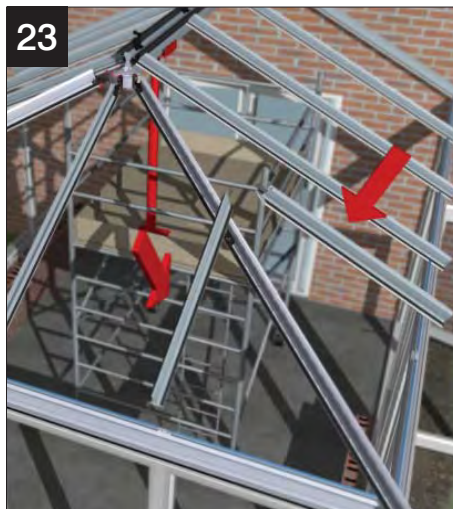

Now start on the jack rafters. The two part jack rafter kit will already be fitted to the hip and jack rafter bars. Again refer to the location plan and corresponding labels attached to the parts.



Each jack rafter kit is supplied with a number of washers. Trial fit the jack rafter and check that the glazing platforms are level. Adjust if necessary by adding or removing washers between the two part connecting kit, then tighten the nut.

INSTALLATION

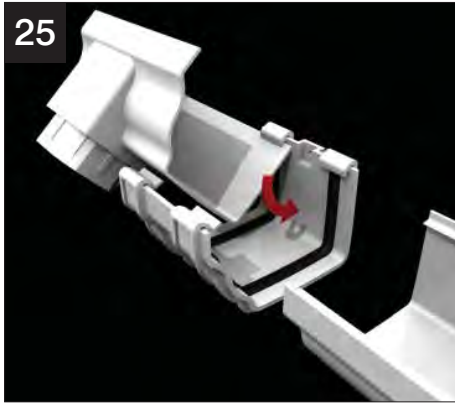

Next, build on the ground the gutter runs, by rolling items like a stopend under the back edge of a gutter jointer.

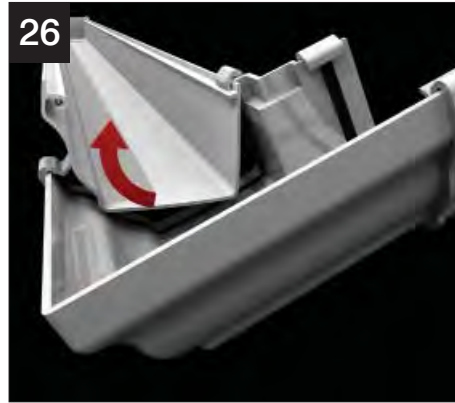

Snap the integral clips on the adaptors over the gutter.



Fit all the gutter brackets supplied with the kit at maximum 750mm centres and maximum 200mm from each corner or gutter union.

N.B. IF USING LOW PITCH FIRING ON GABLE FRAME (BELOW 11°), THE FIRING MUST BE FITTED BEFORE THE CORNICE BASE OR GUTTERING



Locate the back edge of each section of gutter into the slot in the gutter bracket.



Clip the front of the bracket into the lip on the gutter. PVCu components like the gutter are easier to manipulate when warm. In cold conditions more 'force' may be required.



Gutter bracket shown fully engaged.



Ensure the window frames are plumb.

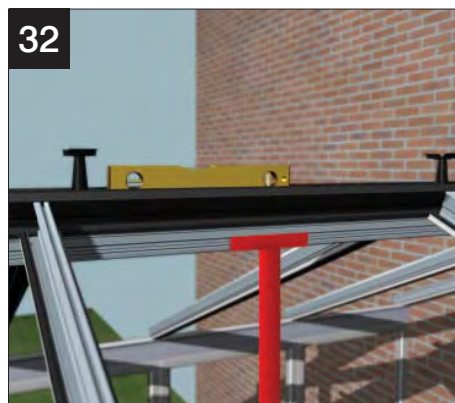

Ensure the ridge is level.



Check that the pitch of the roof is correct. Your Surveyor should have provided a drawing/a copy of the roof confirmation which displays the pitch.

INSTALLATION



Check that the starter bar and first transom bars are parallel.



IT IS IMPORTANT THAT AN ANCHOR BOLT GOES INBOARD AND OUTBOARD OF THE EAVES BEAM.

Fix starter bar back to the host wall using anchor bolts suitable for the substrate (not supplied). A minimum of 4 fixings are required: 2 at the eaves, 1 inboard and 1 outboard as shown; 1 within 200mm of the ridge; plus a minimum of 1 more equidistant between the eaves and ridge. Pack out to support the starter bar behind each fixing before fitting the correct resin anchor (or other suitable alternative).

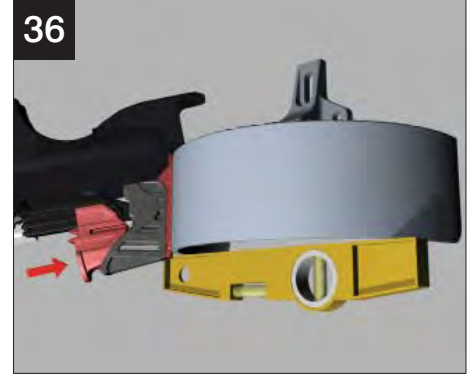

Finally when all is level and plumb, use your thumb to push up the lower wedge which locks into closed position. The roof is now set.

FLASHING

It is at this stage that the stepped flashing is redressed. LEAVE APRON FLASHING UNTIL LATER.

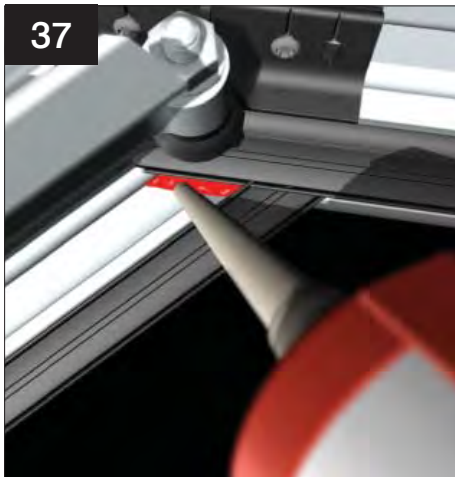

Seal the area where the co-extruded gasket on the hip bar butts against the co-extruded gasket on the jack rafter.

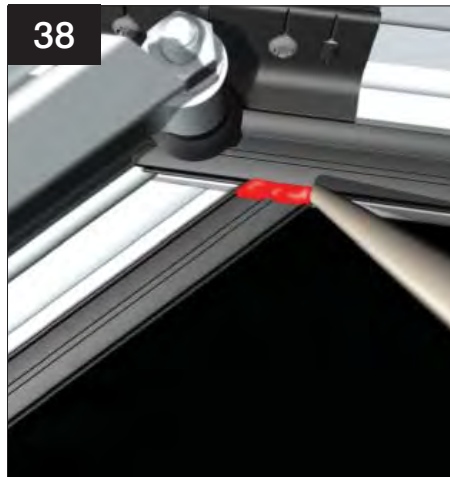

Now glaze the side frames before glazing the roof - this provides additional rigidity whilst working above. **INSTALL TIE BARS(S) BEFORE GLAZING.**



Take the 'soft touch' hub weathering shield. It fits by lifting the flaps on the ridge rain baffle to insert. **NOTE:** The weathering shield will need to be trimmed to suit to fit snugly. See p19/20 for trimming information.

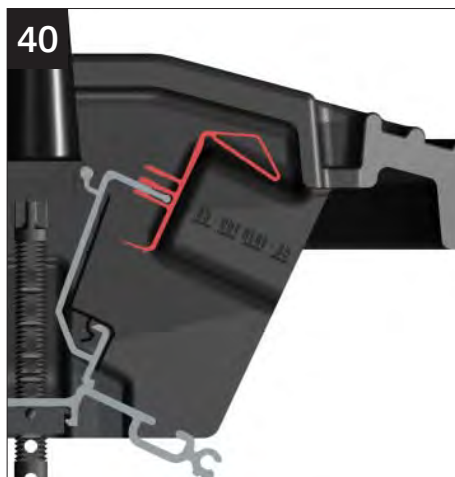

The rain baffle should nestle neatly to form a continuous weather tight joint.



For each glazing bar, 'snip' two small cuts in the weathering shield and then a horizontal cut to remove 'flap' which facilitates the top cap sliding under.



Now glaze the side frames before glazing the roof - this provides additional rigidity whilst working above. **INSTALL TIE BARS(S) BEFORE GLAZING.**

GEORGIAN INSTALLATION - WEATHERING SHIELD CUTTING DETAIL

READ ME FIRST

UP TO 3 STEPS MAY BE REQUIRED

In certain situations it may be necessary to make modifications to the HUB Weathering Shield on site.

Please refer to the table shown to see which steps need to be taken

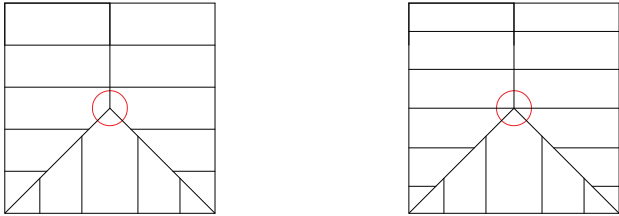

ROOF PITCH	GLAZING THICKNESS	BARS TO FINIAL	BARS NOT TO FINIAL
15 - 24	25mm	FIG. 1	FIG. 1 + FIG. 4
	35mm	FIG. 1 + FIG. 3	FIG. 1 + FIG. 3 + FIG. 4
25 - 30	25mm	NO CUTTING REQUIRED	FIG. 4
	35mm	FIG. 3	FIG. 3 + FIG. 4
31 - 40	25 mm	FIG. 2	FIG. 2 + FIG. 4
	35mm	FIG. 2 + FIG. 3	FIG. 2 + FIG. 3 + FIG. 4

FIGURE 1 - APPLIES TO ALL ROOFS BELOW 25° PITCH

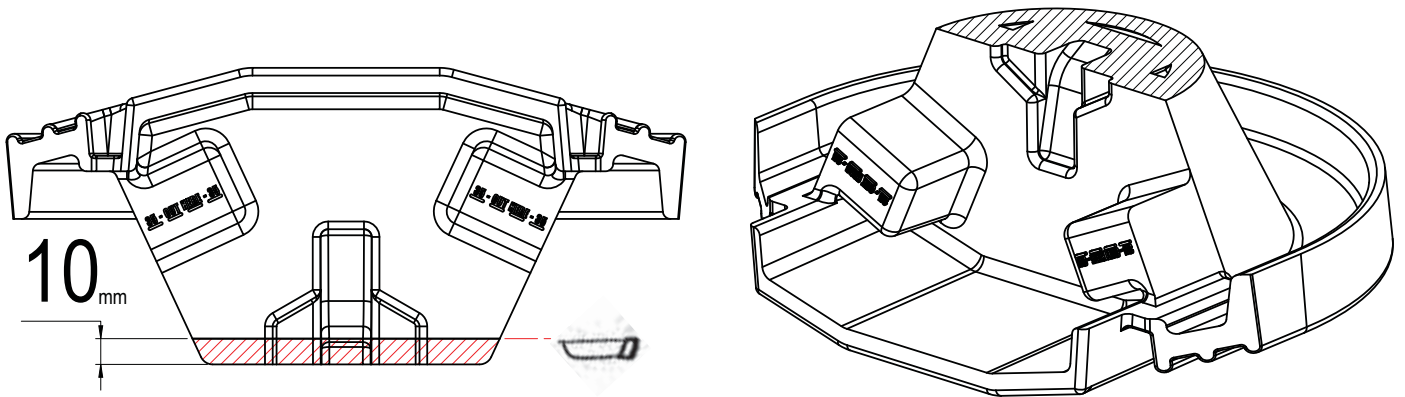

FIGURE 2 - APPLIES TO ALL ROOFS BELOW 30° PITCH

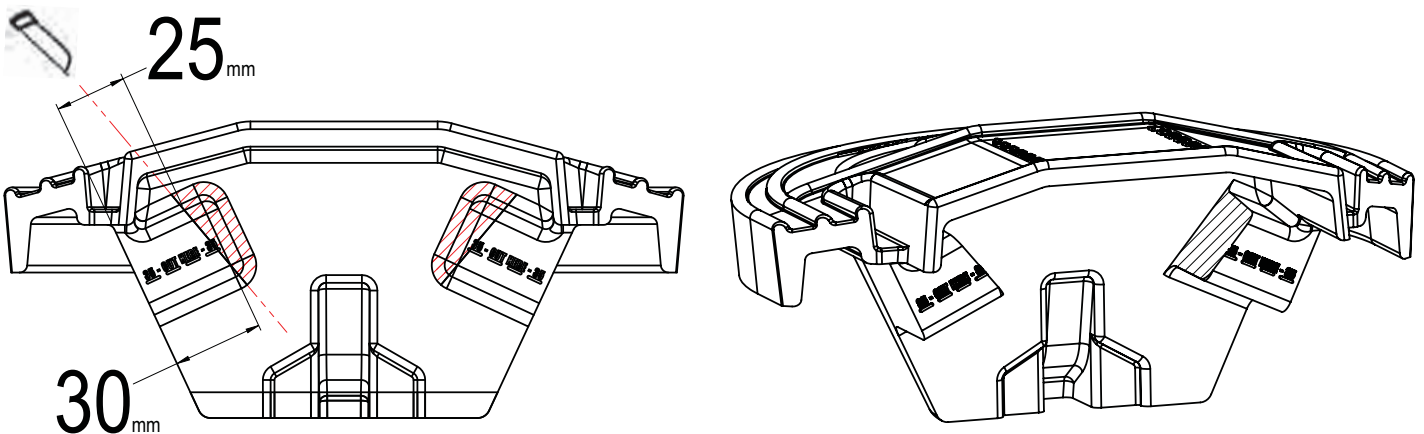

FIGURE 3 - APPLIES TO ALL ROOFS WITH 35MM GLAZING

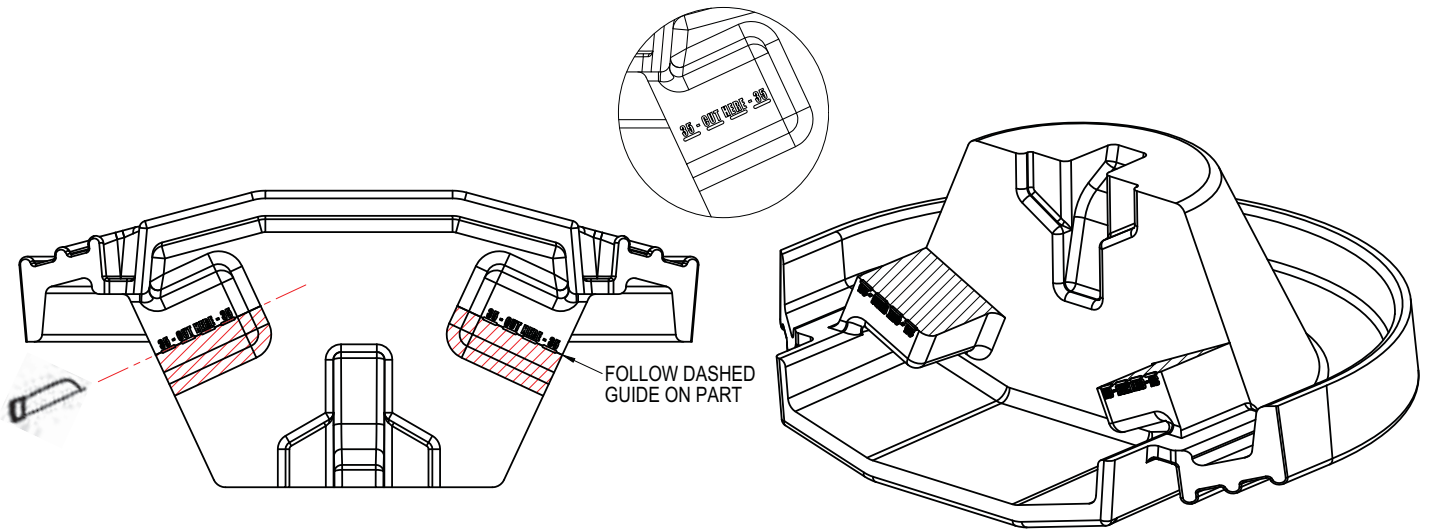
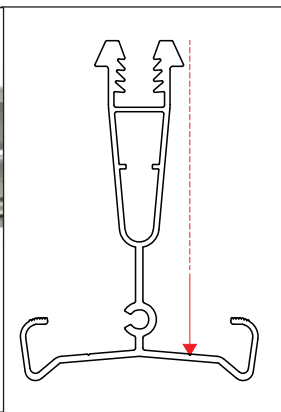
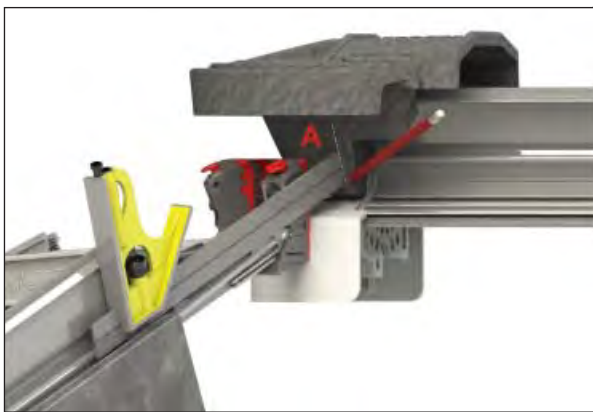

FIGURE 4 - APPLIES TO ALL ROOFS WITHOUT A GLAZING BAR AT THE FINIAL POINT



This step allows glazing to run through when there is not a bar at the finial point.

With all other necessary preps complete, offer up the Weathering Shield into position. Using a straight edge (as shown), project and mark a line 'A' using the glazing 'V' groove (indicated inset) parallel with the centre of the bar closest to the finial point.

Mark line 'B' – this should intersect line 'A' and line through with the 'upper edge of block (25mm glazing) or '35mm dashed line' (35mm glazing) – see below.

Mark line 'C' – this should intersect line 'A' and the virtual 'MIDPOINT' – see below.

Remove segment and repeat on opposite side.

25mm GLAZING

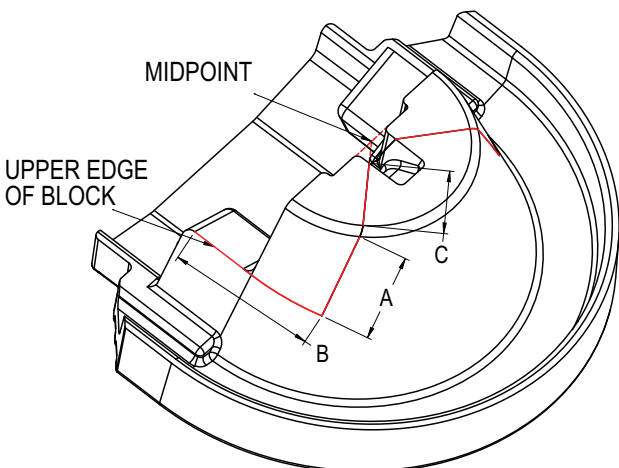
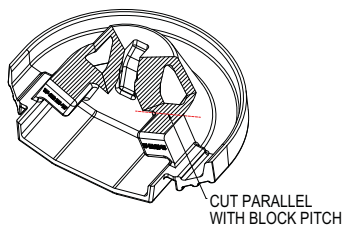

35mm GLAZING

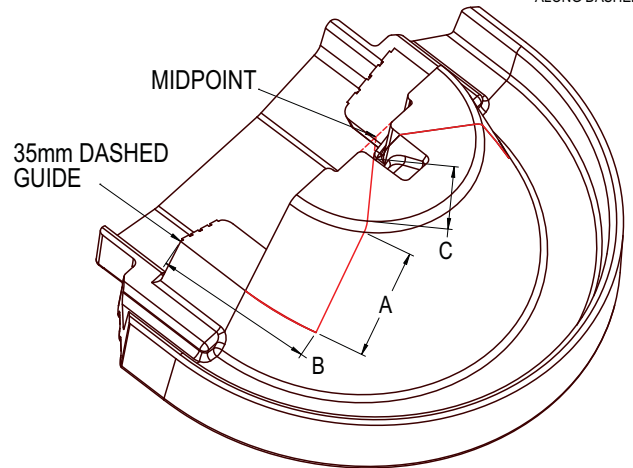
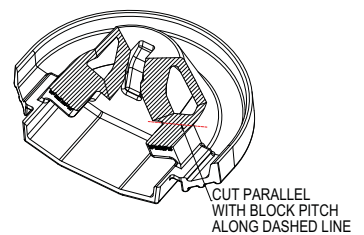

INSTALLATION - STRUTS

STRUTS (every roof has struts) AND TIE BARS (if specified)

BOTH MUST BE FIXED BEFORE ROOF PANELS ADDED (See p43-46 for tie bar arrangements)

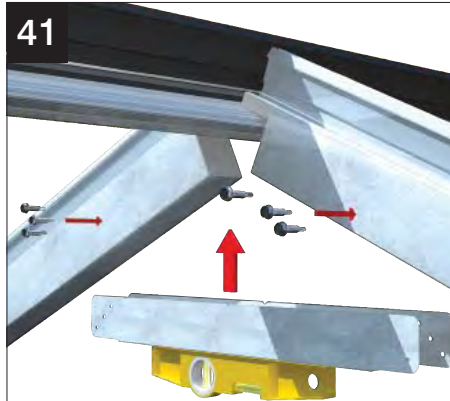

Lift strut into position – check level and fix using Hex head drill screws, 3 fixings per side (12 in total). Attach all struts at this stage.



RRS025
Hex Head Drill screw
5.5mm x 25mm



FIT RADIUS END BRACKET IF SPECIFIED

If a glazing bar is set back from the finial point by more than 150mm, a 2-piece radius end bracket is specified to attach the ridge board (see page 39) attach top 'L' shaped hanger bracket to the ridge body as show, using 2 X Hex head screws (supplied).

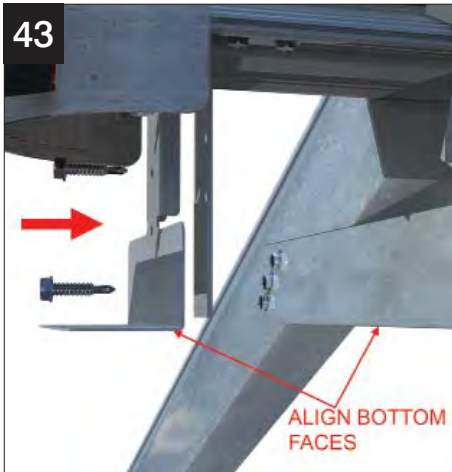

Then attach bottom hanger plate to 'L' shaped bracket, ensuring that its bottom face lines through with the underside of the struts.

NOTE: It may be necessary to trim back the 'L' shaped bracket if it protrudes below the plate.



Now is the time to fit panel end profile. Take the painted profile and protect its surface. Apply a bead of relevant sealant (MS polymer on self cleaning glass). Slide into position on panel, wipe clean any sealant from surface.

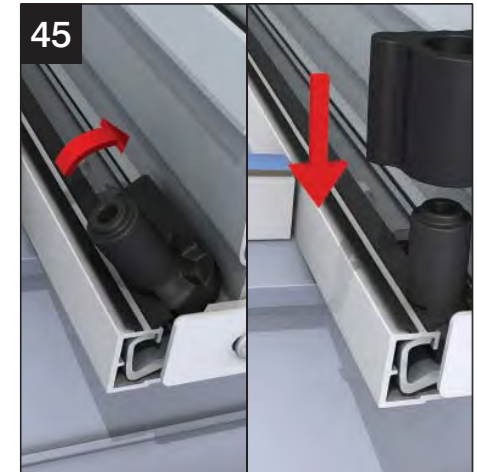

Now it is time to start fitting panel clips. Snap off appropriate handed clip (left hand illustrated). Handing marked on base of clip. Line up the rounded edge on base plate next to central web of glazing bar then tuck neatly under gasket side of bar. Rotate clip into position. Push the grommet over the post as shown.



Slide the complete assembly down the glazing bar, using the endcap fixing block as the 'stop'.



Tease the 'tail' of the glazing support trim tape free (ready to be pulled away when the sealed unit is finally in position).



Centralise the glazing between the glazing bars. If necessary pack it out on each side - press it down onto the support trim.

INSTALLATION

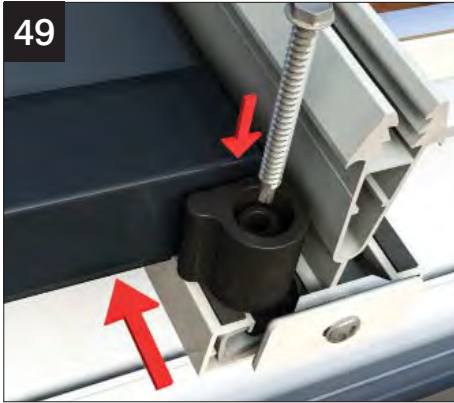

Ensure the glazing end profile sits snugly behind the grommet. Now, using the fixing provided screw down into the bar as shown. **Ensure clip offers maximum support to panels at all times.**

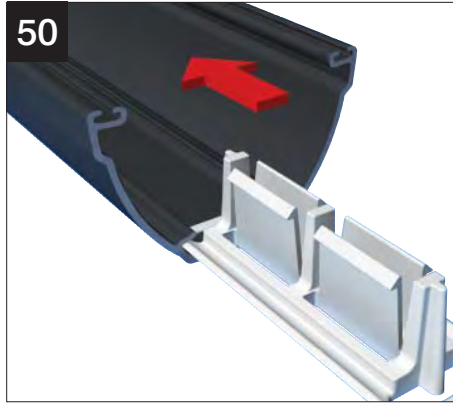

THIS STAGE SHOULD HAVE BEEN PREPPED IN THE FACTORY. If not take the aluminium top caps and lay them onto a protected surface. Slide clips into each bar - position down from ridge / eaves at a max centre of 100mm and then at 500 centres (max) inbetween. **N.B. AT RADIUS END, IT MAY BE NECESSARY TO SLIDE CLIP FURTHER DOWN TOP CAP TO ENSURE ENGAGEMENT WITH GLAZING BAR**

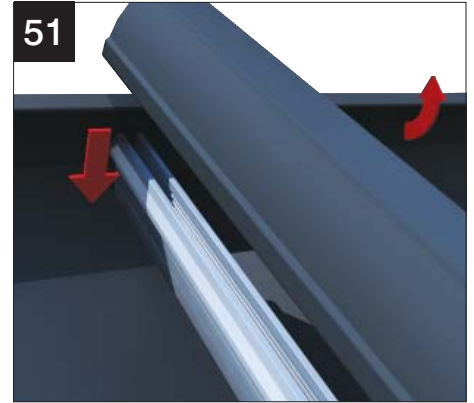

Lift the rain baffle leg and position top cap.

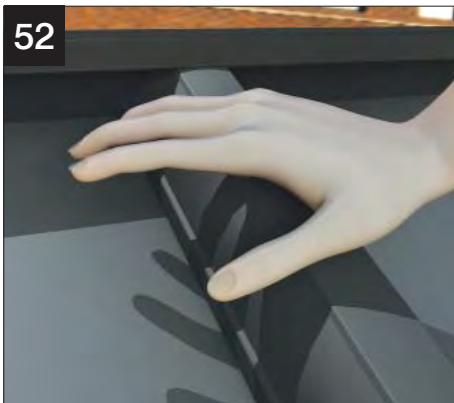

Using the heel of your hand, push down on the top cap to engage the clips, working from ridge to eaves. Ensure the rubber gaskets are full compressed for a watertight seal. NOTE: on longer bars it may be necessary to use a soft mallet and timber block.

IF YOU NEED TO REMOVE A TOP CAP, SEE Appendix 11



Now on the Georgian hip bar tap the glazing bar top cap up until the cut out sits centre to the jack rafter fixing.

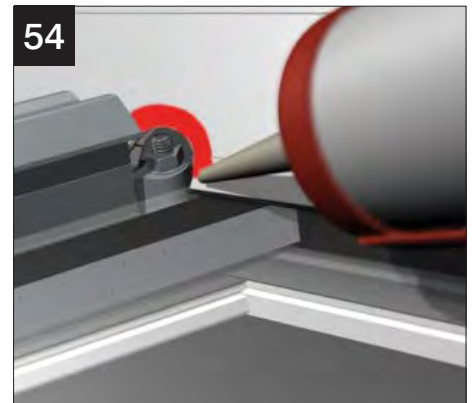

Seal around the notched Georgian top cap ready to receive the jack rafter capping.

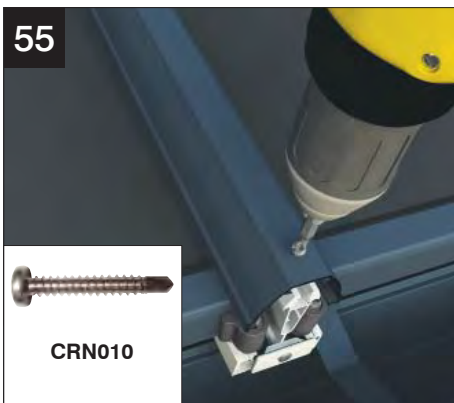

Drill a 6mm hole through the aluminium top cap. Use the fixing provided (CRN010) to attach the top cap to the glazing bar. (Not required if using cornice with wire ties).

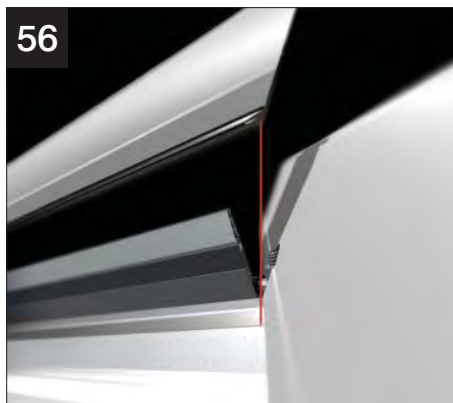

Ensure the jack rafter top capping is lined up correctly (as above) before knocking the top cappings into position.

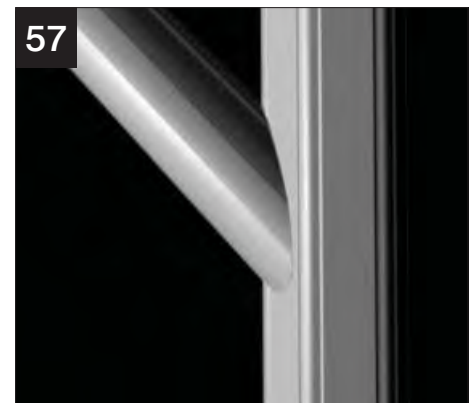

The jack rafter top capping should sit tightly up to the hip bar top capping as shown.

INSTALLATION

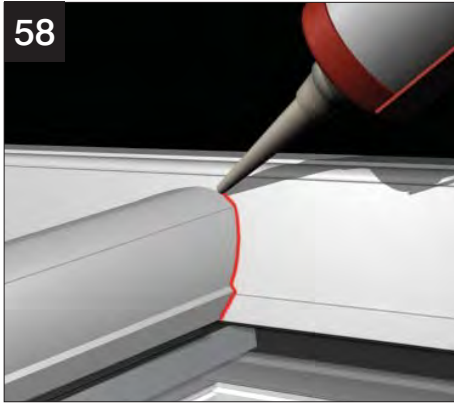

58 Seal around the joint on the jack rafter capping when complete.

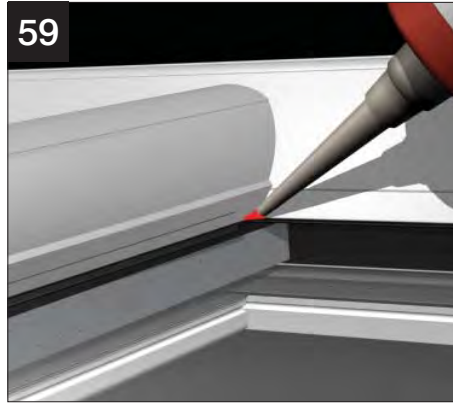

59 Carefully point the corners on each side of the capping where the gaskets abut each other.

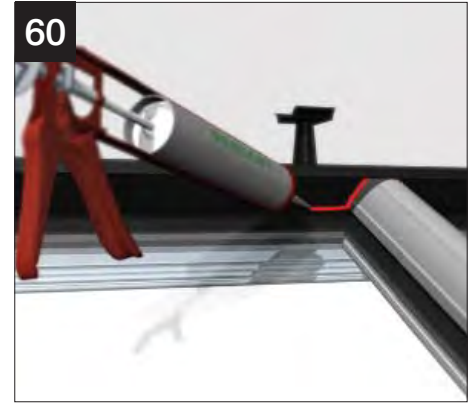

60 Seal around the top of each glazing bar top capping where it meets the rain baffle. Next, run a bead of sealant along the edge where the glazing meets the rain baffle.

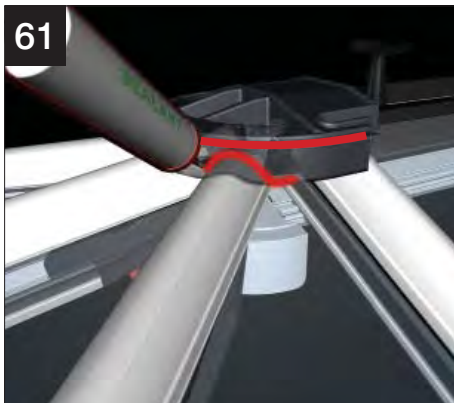

61 Seal around each glazing bar top capping where it meets the inner wall of the 'soft touch' moulded weathering shield. Also apply a bead of sealant to the top edge of the weathering shield so that the ridge capping will seal against it when fitted.

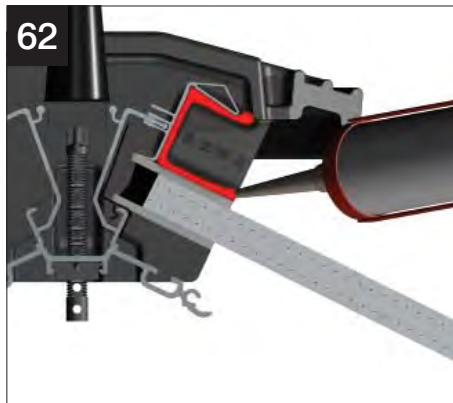

62 Run a bead of sealant in the position shown where the 'soft touch' moulded weathering tray meets the ridge body.

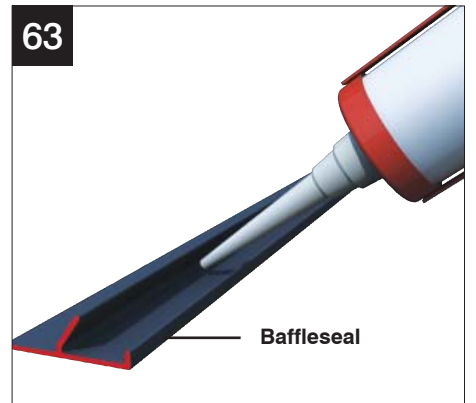

63 An aluminium extrusion is provided to give an additional seal at the ridge. Silicone seal along the length of the 'V' slot.

AT THIS STAGE FIT THE BAFFLESEAL

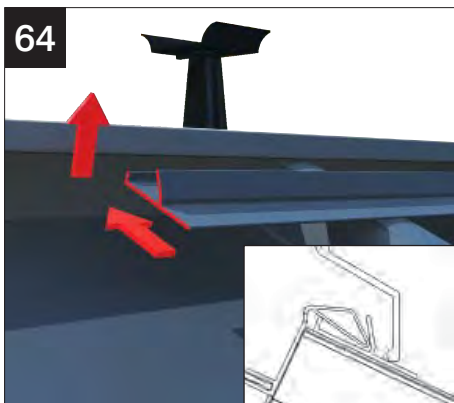

64 Then offer up the extrusion and attach to the rain baffle. Seal into soft touch moulded weathering shield and host wall.



65 Fit the glazing bar end caps by sliding onto the fixing blocks. Push fit the insert into the end cap.

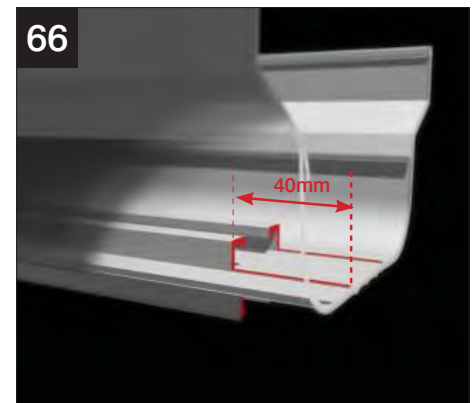

66 Now for the ridge top cap - Cut back the creasting channel on the top and the T bolt slot on the underside of the ridge top capping by 40mm.

INSTALLATION

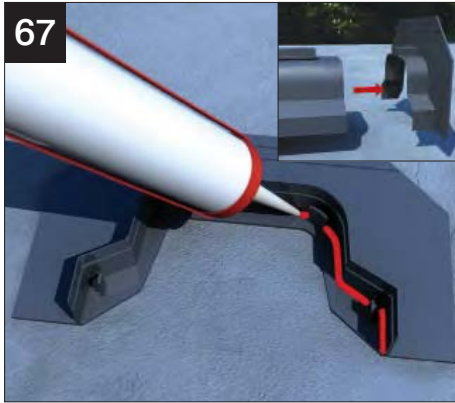

67 Apply a bead of sealant into the channel of the ridge flashing trim before fitting and then slide into position.



68 Screw the flashing trim to the ridge top cap through the screw port. Use a 4.2mm x 13mm self drilling screw (not supplied).

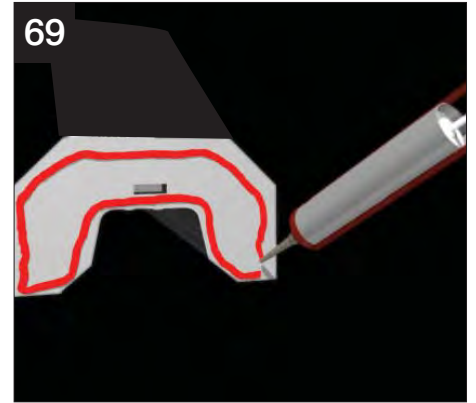

69 Apply a generous amount of sealant to the back edge of the flashing trim.



70 Offer up the complete ridge capping onto the roof.

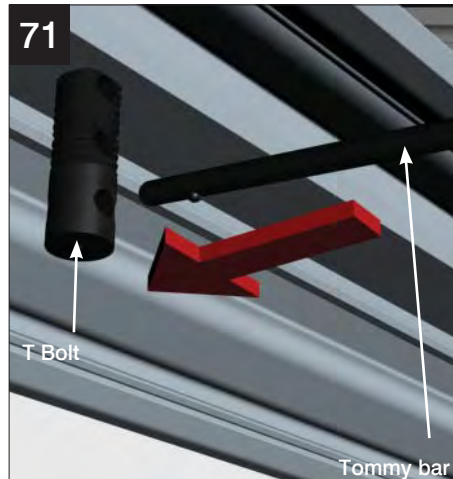

71 From the inside of the conservatory insert the snap off tommy bar into the T bolt.



72 Twist through 90° to locate the T bolt into the ridge capping.

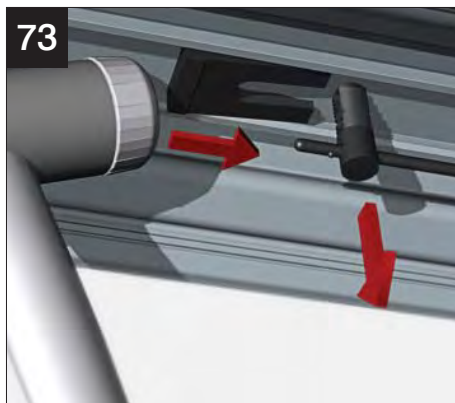

73 Pull down on the T bolt and tap the fixing wedge into place to secure the T bolt. Cut off the excess T bolt below the fixing wedge.



74 Attach fascia board to barbs built into the eaves beam.

IF YOUR DESIGN FEATURES A VALLEY SEE APPENDIX 4

INSTALLATION - INSULATION SLABS - PELMET

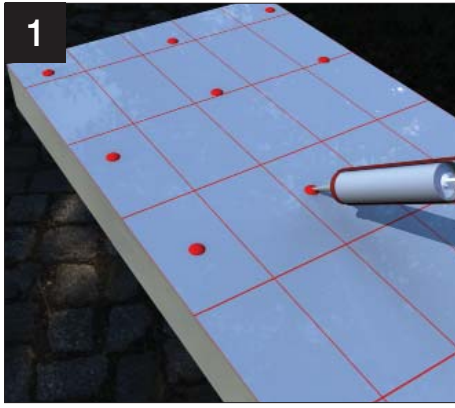

Now moving onto the installation of the insulation. Take the 90mm insulation board – each part is numbered/lettered to identify where it goes (label always to the inside of the conservatory). Spot the board with sealant.

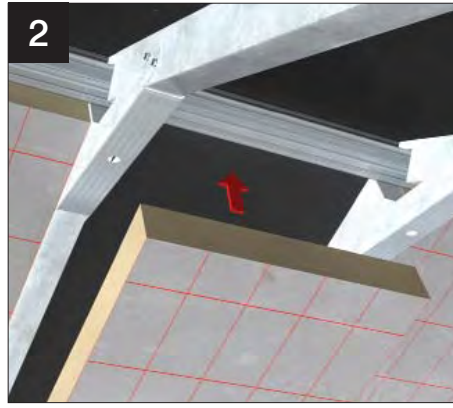

Insert the board into position between bars and ensure sealant 'grabs'.

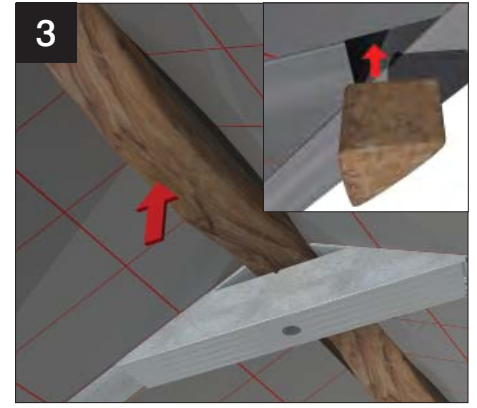

Fill ridge voids – including the ridge radius end – using the mineral wool supplied (2 x 12m x 190mm wide rolls). In jack rafter positions, use a piece of mineral wool to ensure the potential for cold bridging is minimised.

INSTALLATION

- BOLSTER CLADDING TRIMMING DETAIL & BATTEN POSITION

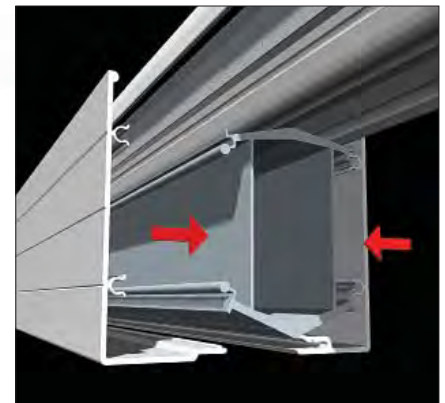
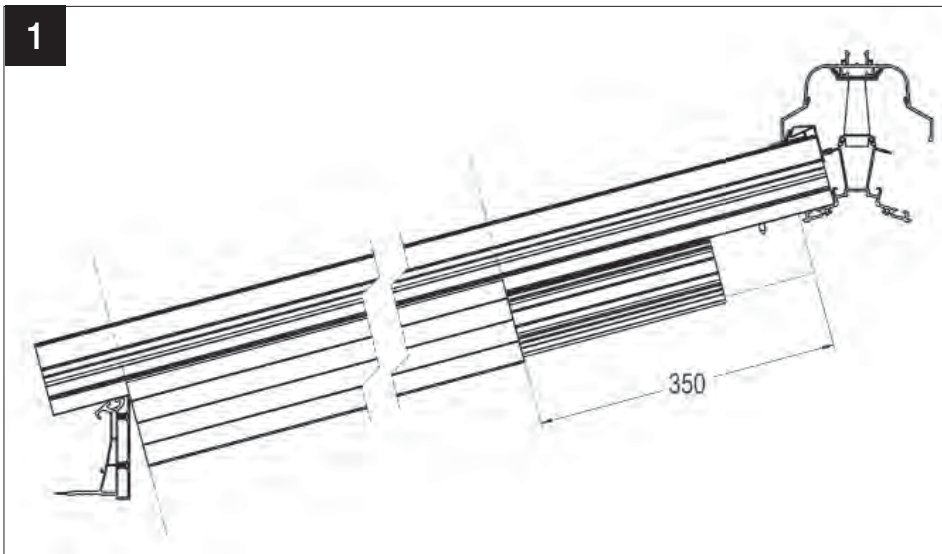

Take the two part cladding, attach each piece carefully to the aluminium bolster profile and 'zip' together.

IF A BOLSTER BAR IS FITTED TO A GLAZING BAR IT IS NECESSARY TO FIT THE PVC BOLSTER CLADDINGS BEFORE THE INSULATED INTERNAL PELMET BRACKETS. When fitting the second row of battens (as described on page 40) notch the batten (8mm deep X 38mm wide, see below) to allow it to fit over the bolster. Trial fit bolster claddings, mark and cut to length.

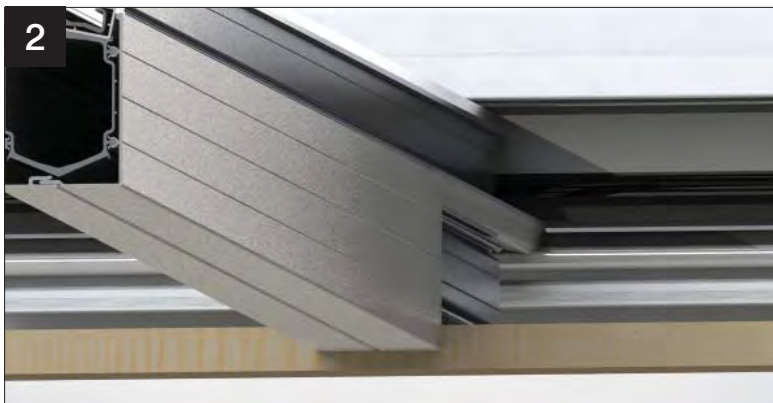



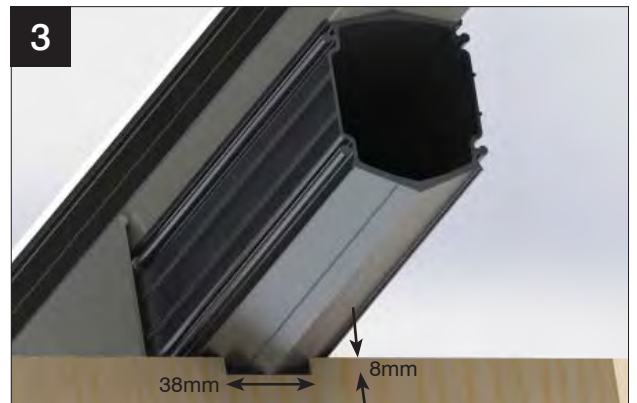





















This is how final installation should look.



N.B. IT IS CRITICAL TO POSITION THE PVCU CLADDING 350MM AWAY FROM THE RIDGE

COMPONENT PARTS LIST

 <p>CHA405/1 Perimeter Channel - PIERCED CHA405/2 Perimeter Channel</p>	 <p>CHA405/3 Crossrail Channel</p>	 <p>Bolster Corner Infill</p>	 <p>CHAA019 L/R Gable / solitary glazed panel bracket</p>
 <p>CHA001 Transom Bracket</p>	 <p>CHA090 Georgian Hip Bracket</p>	 <p>CHA003 Hip Bracket Adjustable</p>	 <p>CHA011 Splay Bar Bracket Assemble</p>
 <p>CHA013L Closure Trim Support Bracket LH (Bolster)</p>	 <p>CHA013R Closure Trim Support Bracket RH (Bolster)</p>	 <p>CHA009 Bolster Transom Bracket</p>	 <p>CHA010 Bolster Hip Bracket Assembly</p>
 <p>CHA012 Bolster Splay Bar Bracket</p>	 <p>CHA006 BAG OF 25 - M4 x 13 Self Drill Philips Wafer Head</p>	 <p>CHA007 BAG OF 25 - 4.2 x 19 Self Drill Philips Head Screw</p>	 <p>CHA008 BAG OF 25 - 4.8 x 32 Self Drill Philips Pan Head</p>
 <p>CHA002 Poly Panel Spring Clip</p>	 <p>CHA004 Poly Support Wire Form Bolster Spacer</p>	 <p>CHA015 Super Duty Eaves Poly Support Clip</p>	 <p>CHA200/7 Vent Foam</p>
 <p>CHA600GR/5 & CHA300/6 Top Cavity Closing Trim & Sealing Foam</p>	 <p>CHA300/GR/4 1.25mm Plaster Stop Edge Bead - Painted</p>	 <p>CHA165 or CHA265 Gallows Packer 165 or 265</p>	 <p>CHA005 Single Tie Bar Cover</p>

Should you find damaged or missing components, please always reference replacements with both a parts code (see above) and/or its position on the location plan. This will help with the speedy resolution of any issues.

PRE - PREPARATION - GALLOWS BRACKET

Packer / Spacer slips over



Finished installation you need to find

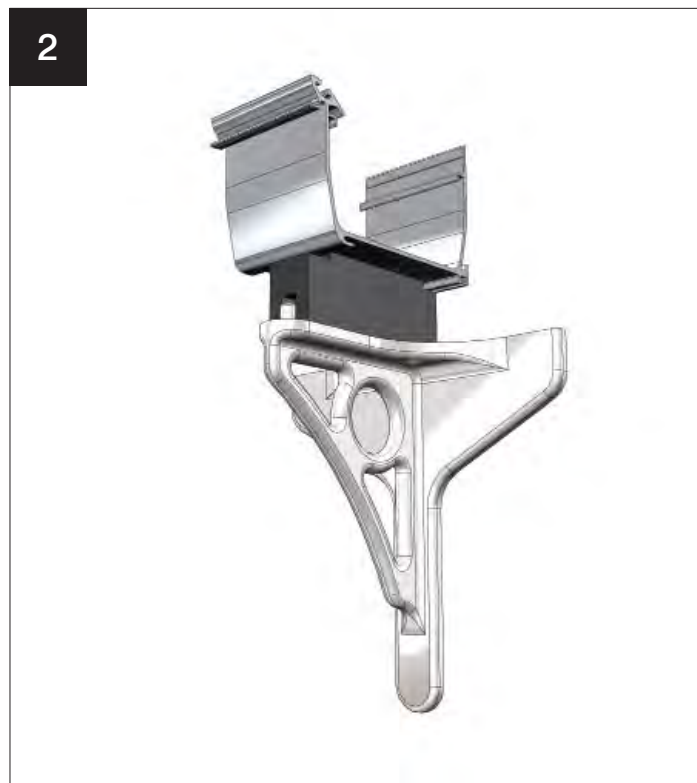

Gallows brackets and packers must be installed BEFORE glazing. Structurally it is NOT permissible to insert this packer / spacer when the roof is already glazed.

Box Gutter - 165mm

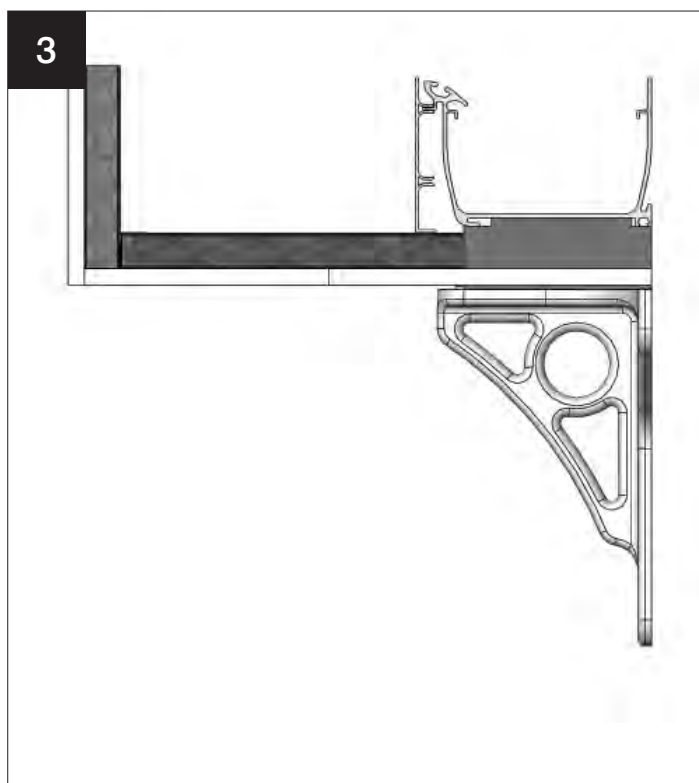

Box Gutter - 265mm

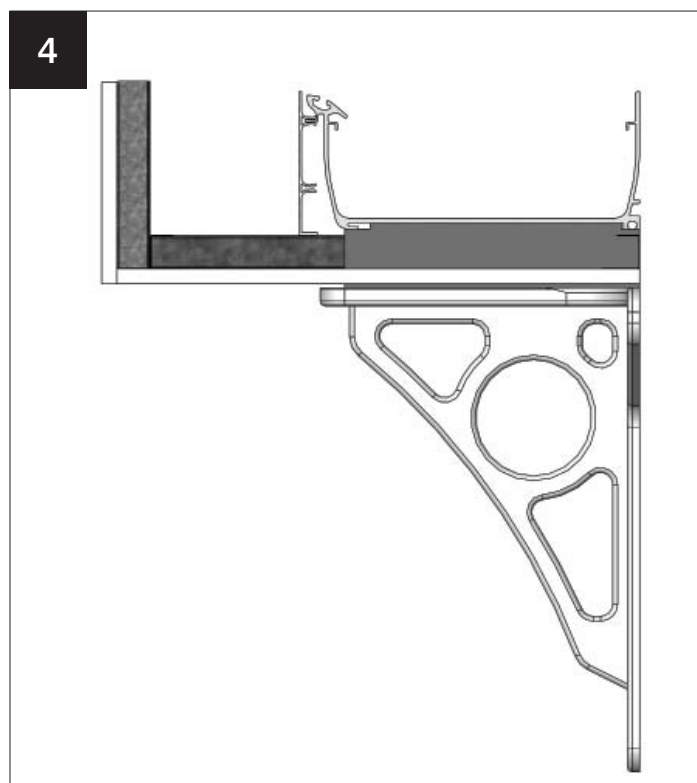

INSTALLATION - PELMET BRACKETS

IF YOUR DESIGN FEATURES GLAZING BOLSTERS SEE APPENDIX 2

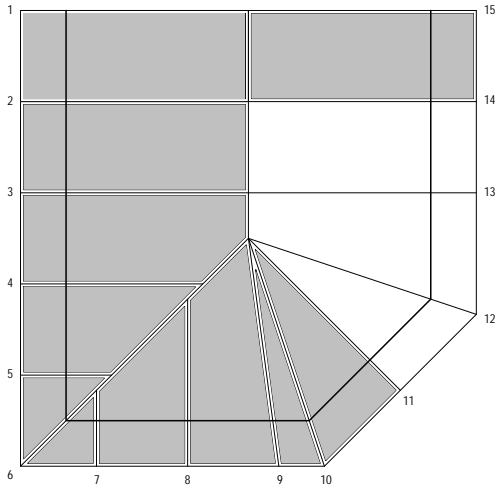

NOTE: FOR GABLE FRAME CONSERVATORIES – READ IN CONJUNCTION WITH APPENDIX 6

OVERVIEW

IMPORTANT NOTE: Left (L) and right (R) dimensions are viewed internally.

STANDARD BRACKET BAR POSITION(S)	CHA001 (mm)	CHA003 (mm)	CHA090 (mm)	CHA001 (mm)	CHAA019L (mm)	CHAA019R (mm)
1-5, 7-8, 15	S-142					
6			S-97 L/R			
9				S-143 L/R		
10		S-176 L/R				
11	S-142				G-182 R	
12		G-248 L/P				
13	G-248					
14	S-142					G-182 L

PREFIX S: SOLID PANEL
PREFIX G: GLASS PANEL

EXAMPLE
refer to separate location plan

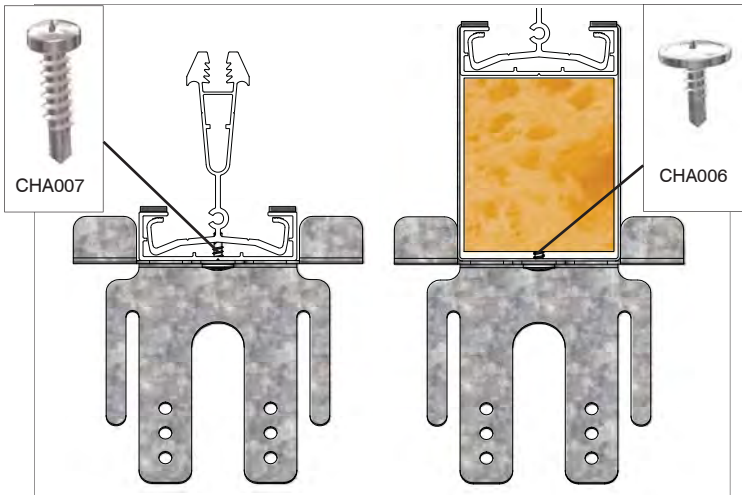

GENERAL NOTE ON BRACKET FIXING 1: Bracket fixing screws must be fit central of glazing bar, mark up the centre line of the bar on to the undercladding if it is not clear by sight.

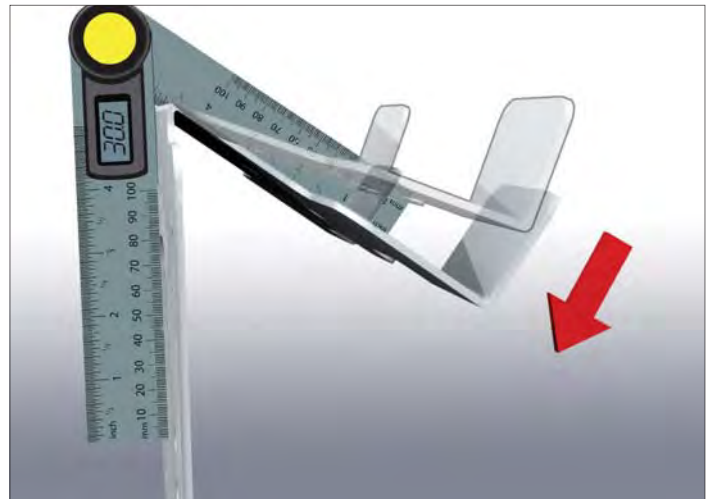

GENERAL NOTE ON BRACKET FIXING 2: Fitters tip - prep all of the brackets by BENDING to pitch before attaching to bars.

INSTALLATION - TRANSOM BRACKETS

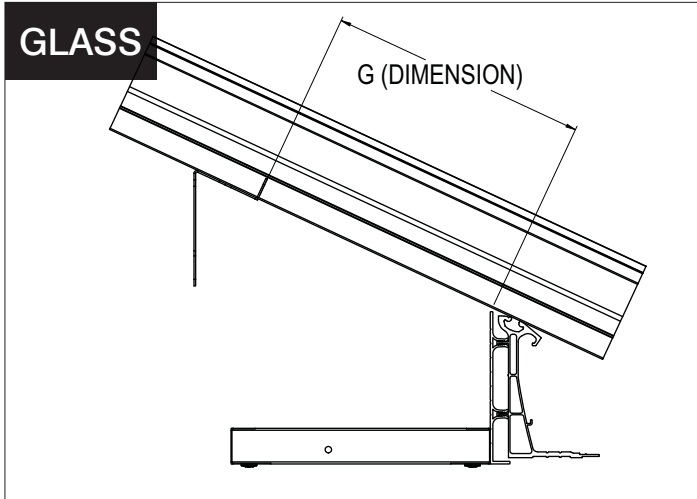

Measurements are **ALWAYS** from the top edge of the PFTB fascia board when glazing is being inserted in to the bar.

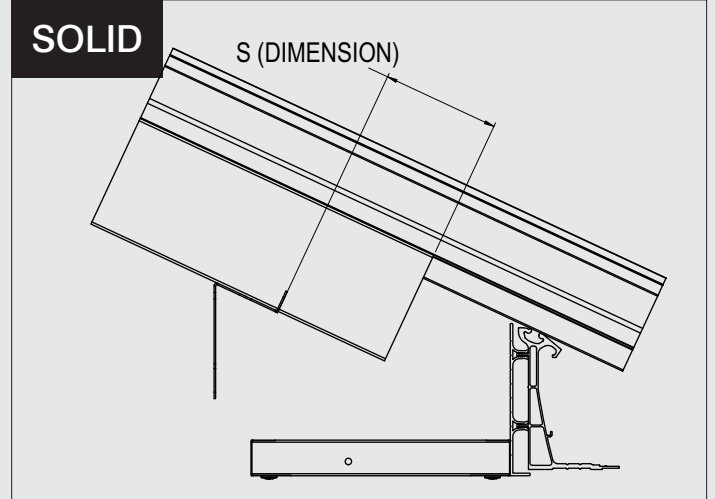

Measurements are **ALWAYS** from the bottom edge of the steel bolster when solid panel is inserted into bar.

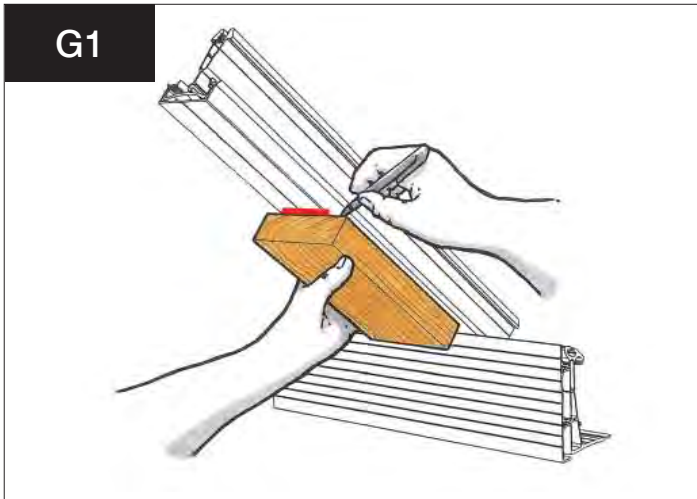

Using the location plan provided – see example above - find the dimension for setting out clip positions on the transom bars. Measure up the bar from top edge of fascia board, and mark it. If your roof features many transom bars, it may be simpler to cut a piece of timber to length and use as a template.

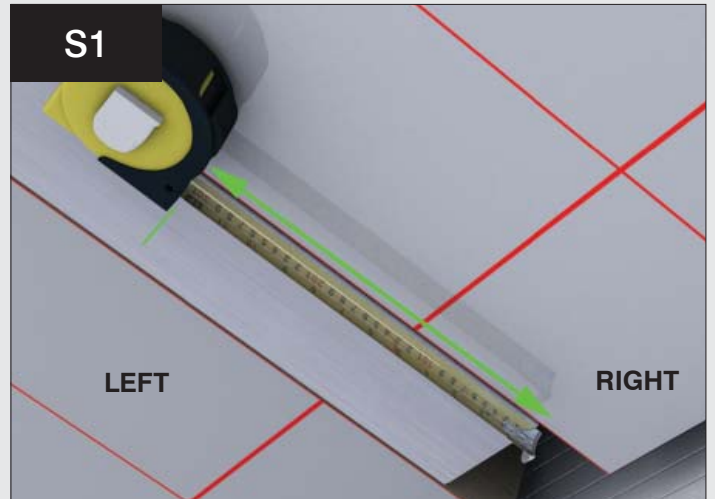

Using location plan provided, measure up and mark from bottom of steel bolster.

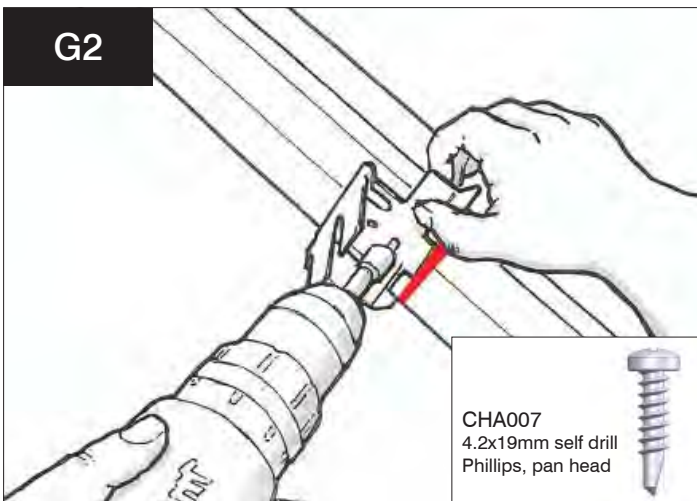

Take the transom bracket (CHA001) and attach using two 4.2 x 19mm self drill Phillips pan head screws supplied- the back edge of the bracket should butt up to the pencil line.

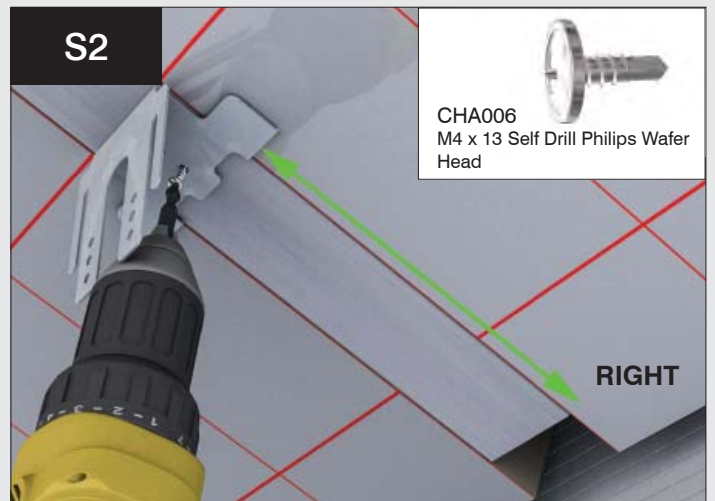

Take the transom bracket supplied and attach using fixings provided.

INSTALLATION - STARTER BAR BRACKETS

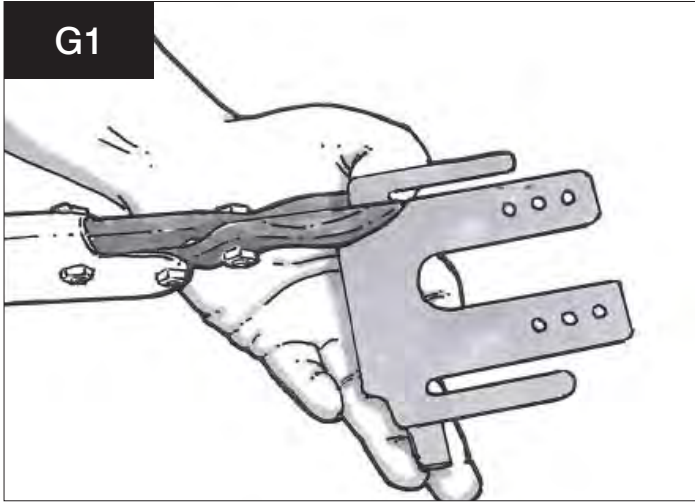

On the starter bar, take a CHA001 Transom bracket and snip off the long leg tab – if the wall is already plastered, further trimming maybe required.

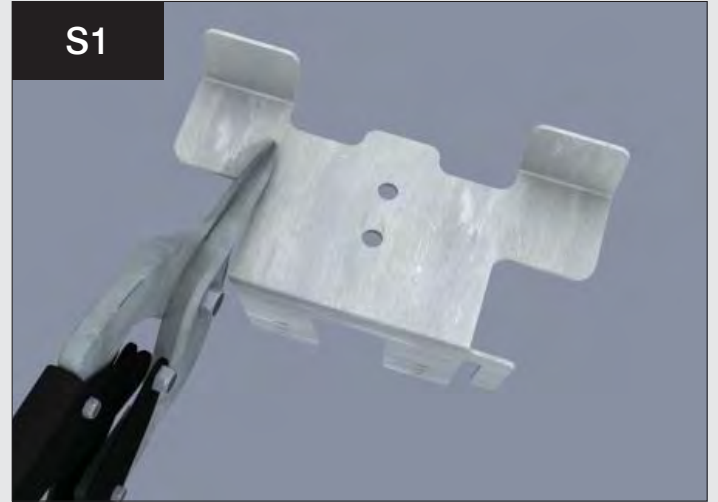

Take a CHA001 and snip off the ear (depending upon hand) if wall is plastered, further trimming maybe required.

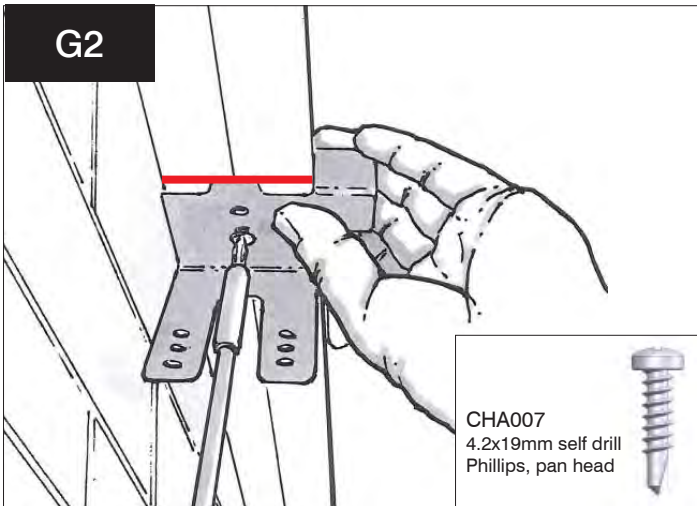

Measure, mark and fit the trimmed down starter bracket using two 4.2 x 19mm self drill Phillips pan head screw.

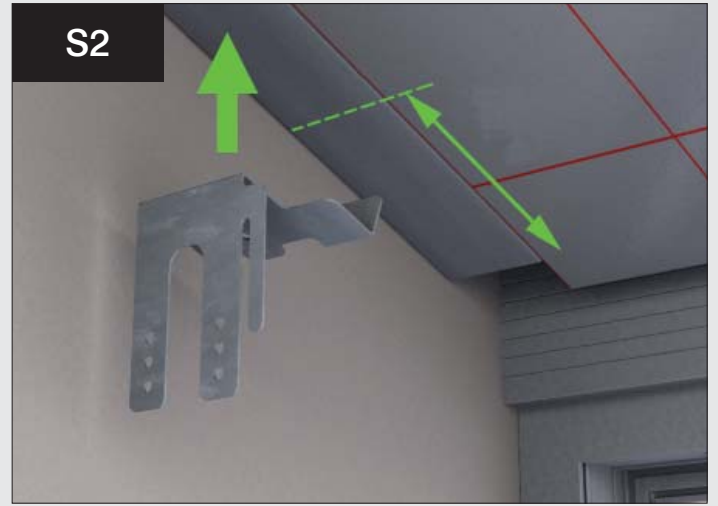

Measure, mark and fit the trimmed down starter bracket using two M4 x CHA006 13mm self drill Phillips pan head screw.

INSTALLATION - TIE BAR BRACKETS (SOLID PANEL)

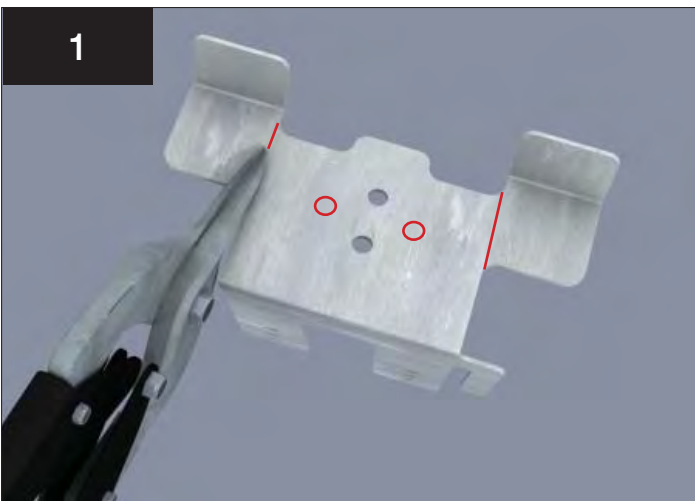

Take a CHA001 Transom Bracket and remove the 'ears' from both left and right as indicated. Drill additional holes as shown to allow access when in position.

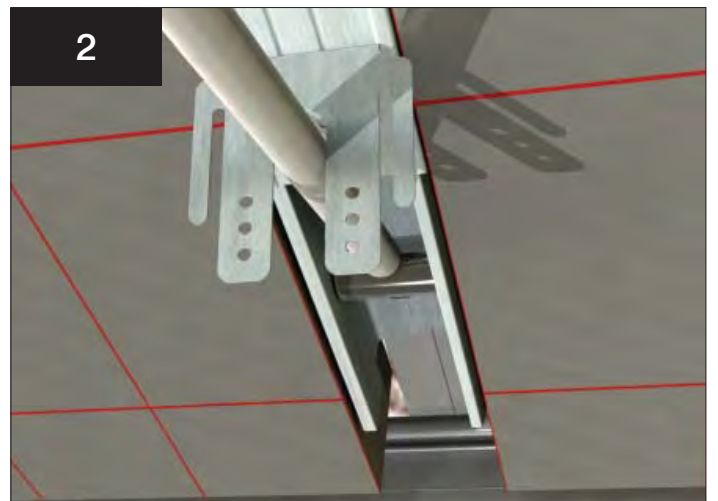

Measure, mark and fit the trimmed down starter bracket into position around the tie bar conduit as shown.

INSTALLATION - HIP BRACKETS

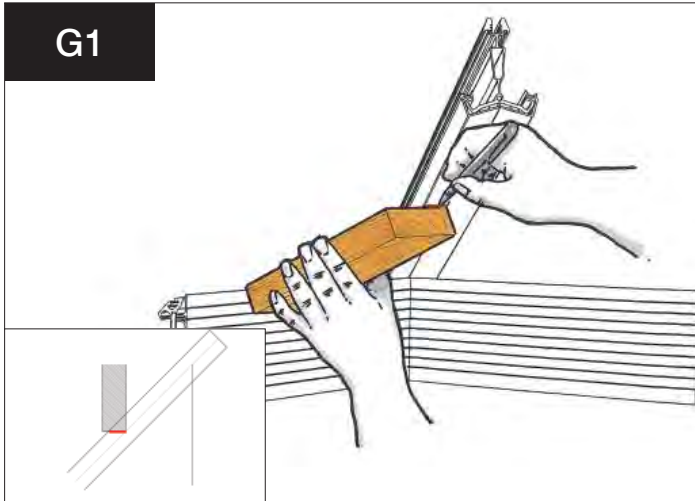

Similar to step 16, seek the set out dimension from the location plan (12) for the Georgian or Victorian bar. Mark with a pencil line. Please note the dimension will be different from the transom bar. This graphic shows the left hand dimension being marked. Timber template to be held square to fascia board. Now mark right hand position.

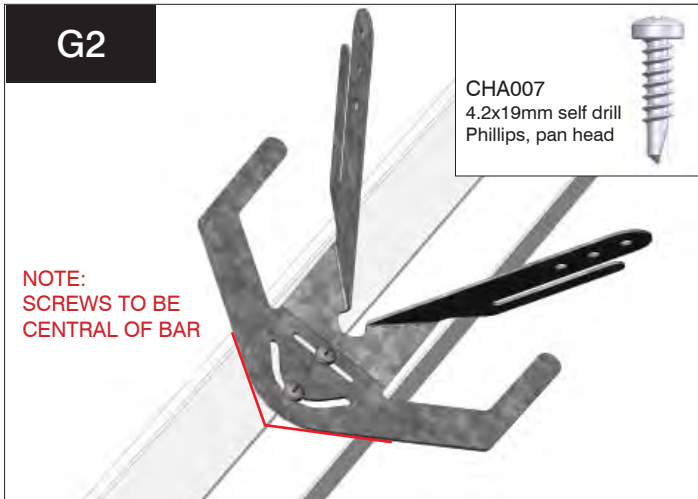

Now attach using one of the two 4.2 x 19mm self drill Phillips pan head screws supplied – one screw curved top slot - do not 'nip up' at this stage, but allow bracket to pivot.

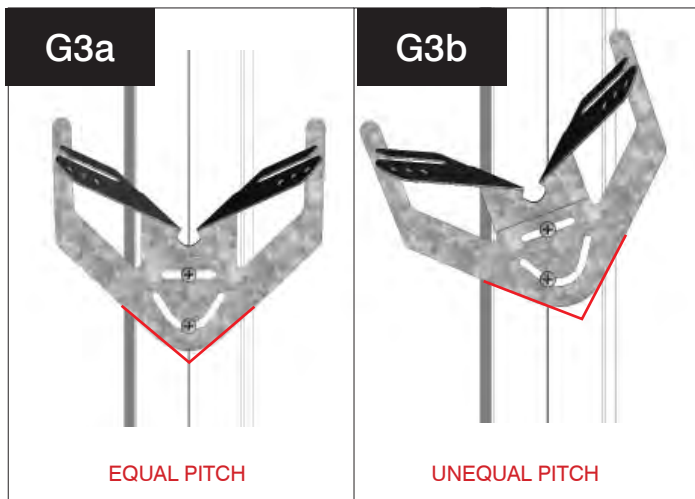

Where the roof is equal pitch across the hip, the bracket should sit as (a). On unequal pitches, the bracket may be skewed as in (b).



Having attached all the transom brackets, using a string line or straight edge mark across to each side of hip bar.

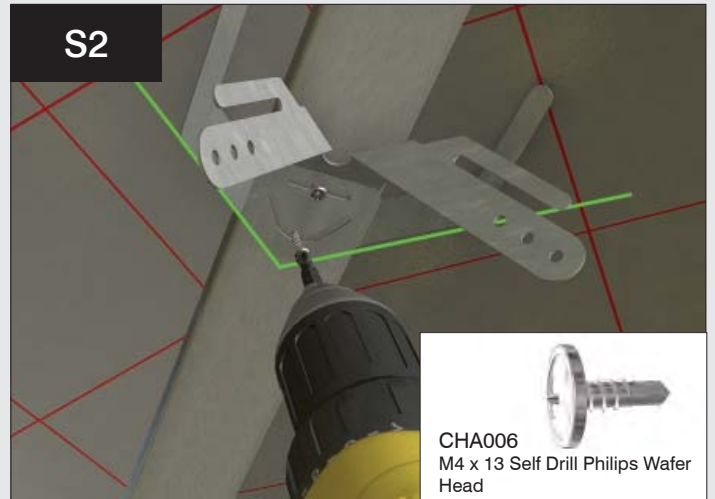

Now attach using one of the two M4 x 13mm self drill Phillips pan head screws supplied – one screw curved top slot - do not 'nip up' at this stage, but allow bracket to pivot.

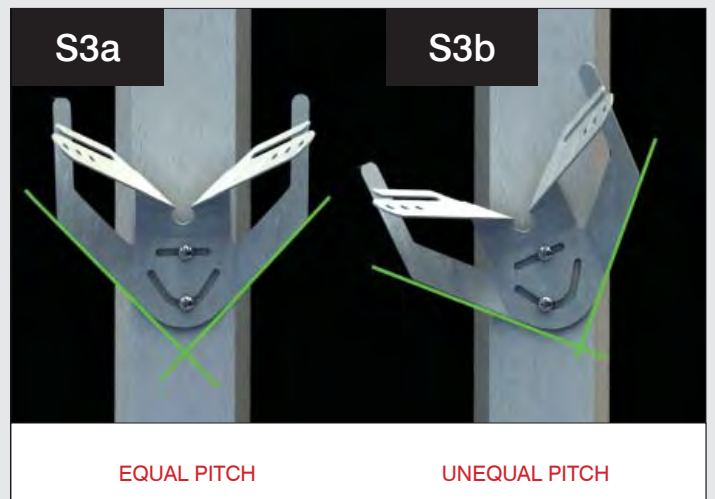

Where the roof is equal pitch across the hip, the bracket should sit as (a). On unequal pitches, the bracket may be skewed as in (b).

INSTALLATION - SPLAYED BAR BRACKETS

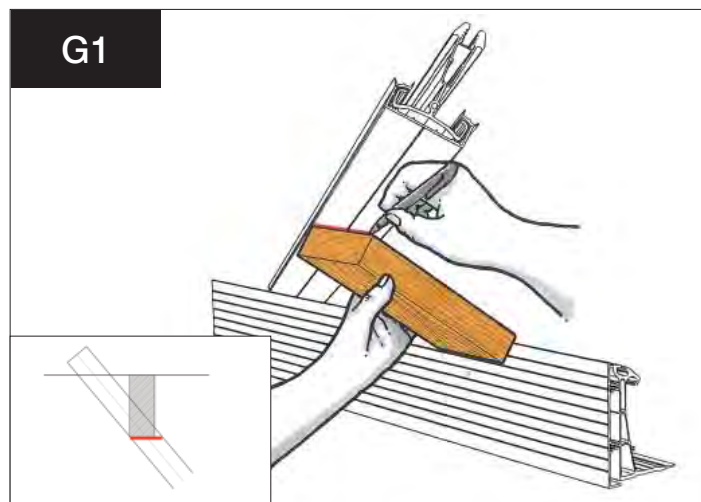

G1
On a splayed bar – 7 and 8 on the sample location plan – measure and then strike a line across the face of the splayed bar's undercladding. Timber template to be held square to fascia board.

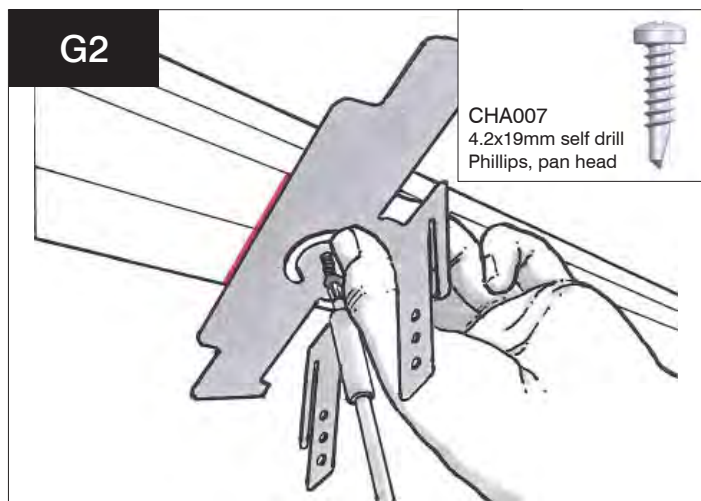

G2
Now attach bracket CHA011 using one 4x19mm self drill Phillips pan head screw - ensure screw is in centre line of bar.

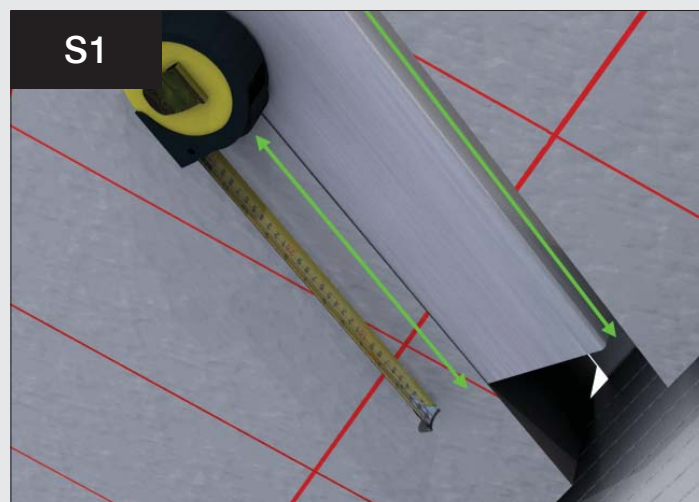

S1
Using the location report, measure and mark both sides of splayed bar.



S2
now attach bracket CHA011 using one m4x13mm self drill Phillips wafer head screw - ensure screw is in centre line of bar.

GLASS PANEL BRACKET FOR ALL BAR TYPES (GLASS/SOLID INTERFACE)

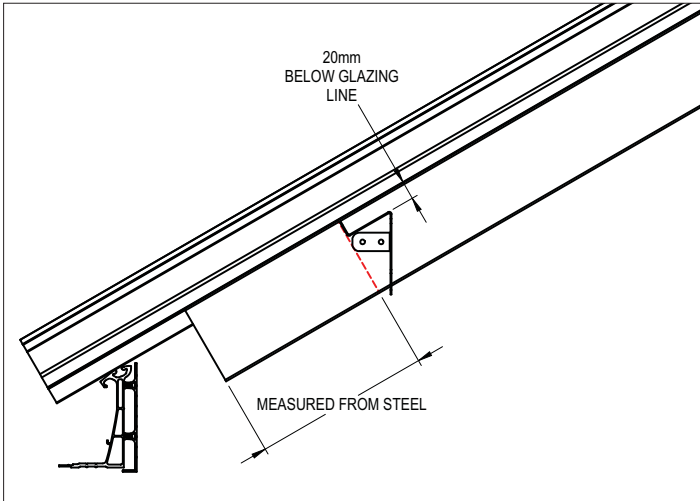

Transom / Hip position

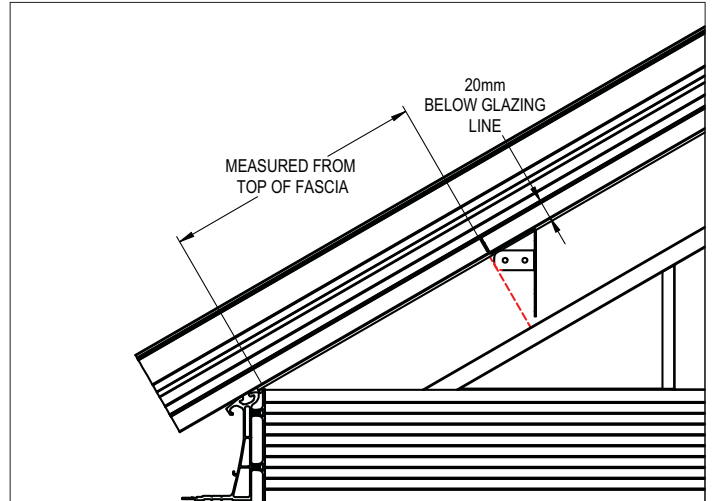

Gable position

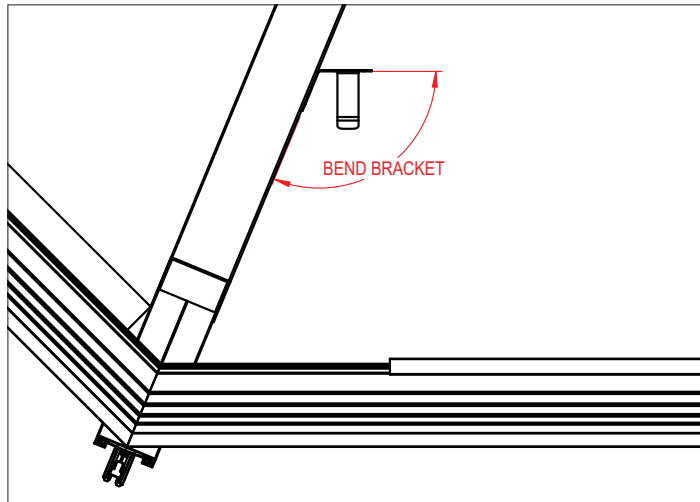

Hip position

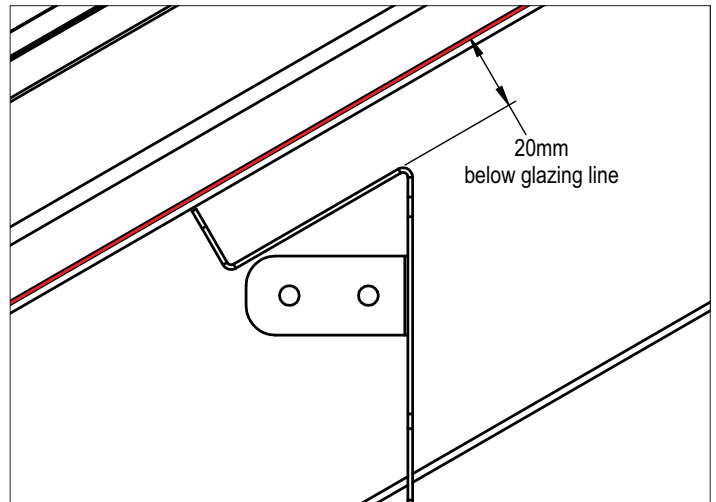

Close up detail

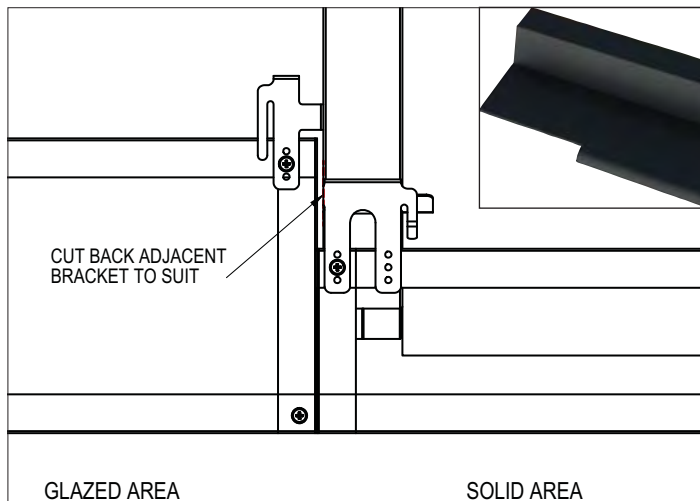

Typical Transom. Cloaking panel support trim will require notching.

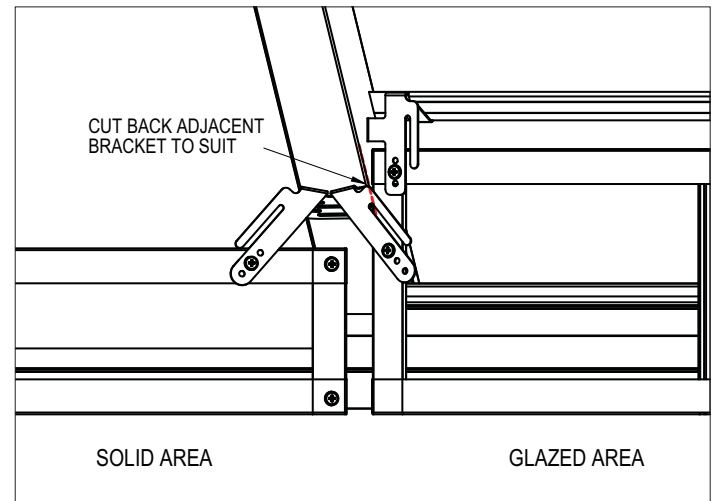

Typical Hip

INSTALLATION - CLOAKING PANEL CLIPS ON GLAZING BARS

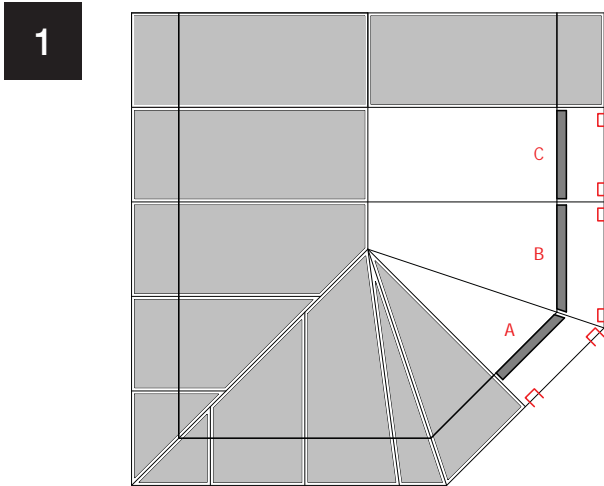

Symbol '☐' shows if one support clip is needed central to the bar or one each adjacent to the bar - see steps 2 and 3 below.

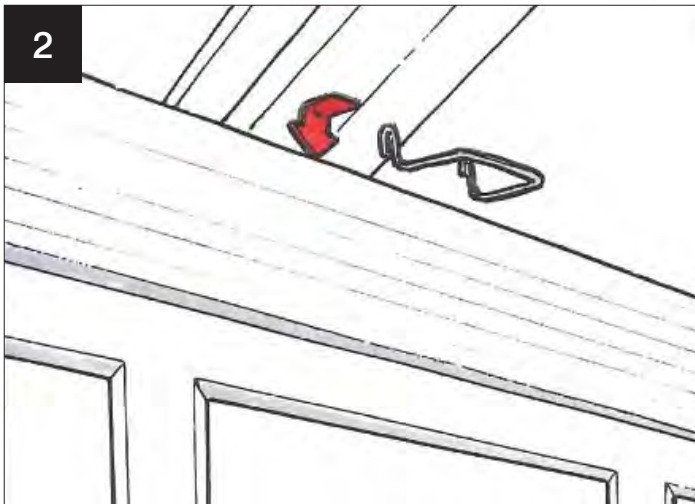

Over the planked fascia board at the eaves, at each transom (but not tie bar locations) and splayed bar position, hook over the cloaking panel support clips CHA002.

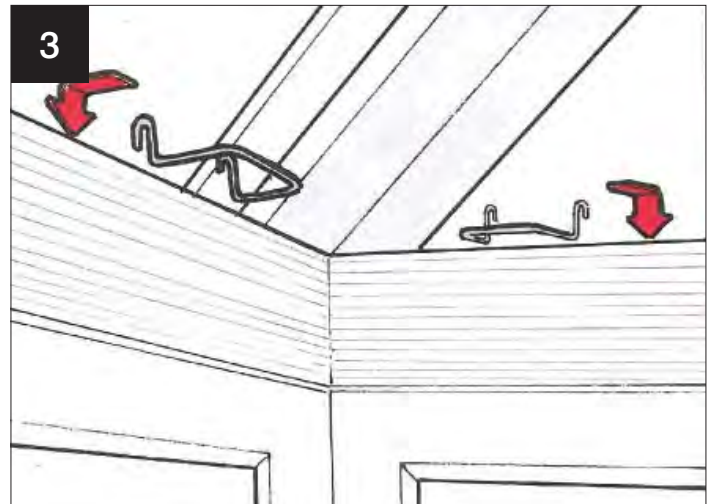

On starter bars, hip bars and transoms with tie bar brackets, a cloaking panel support clip is placed each side of the bar.

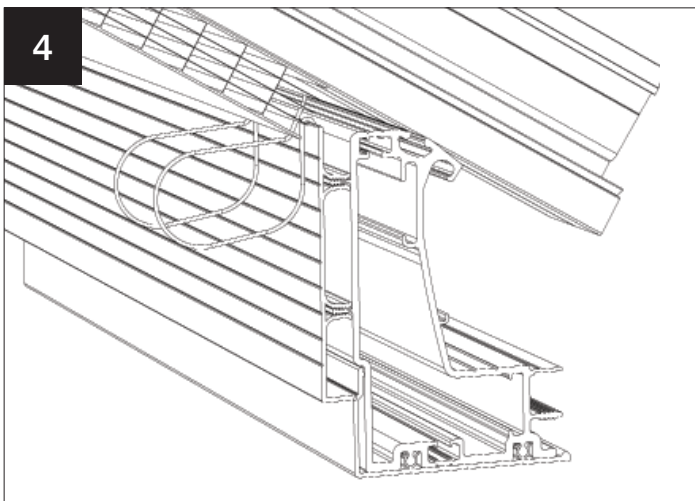

IMPORTANT NOTE: If Super Duty eaves beam is used, then these are the cloaking panel clips that are supplied (CHA015).

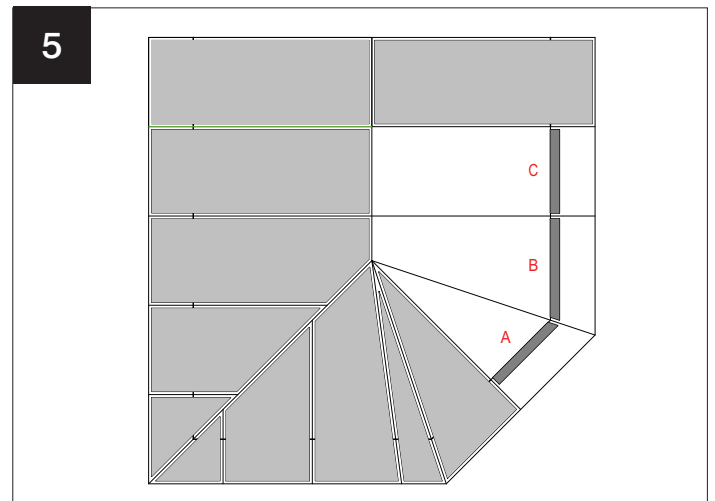

Select the cloaking panel (polycarbonate) support trim for the positions indicated in Black (A, B, C).

INSTALLATION - CLOAKING PANEL CLIPS - EAVES

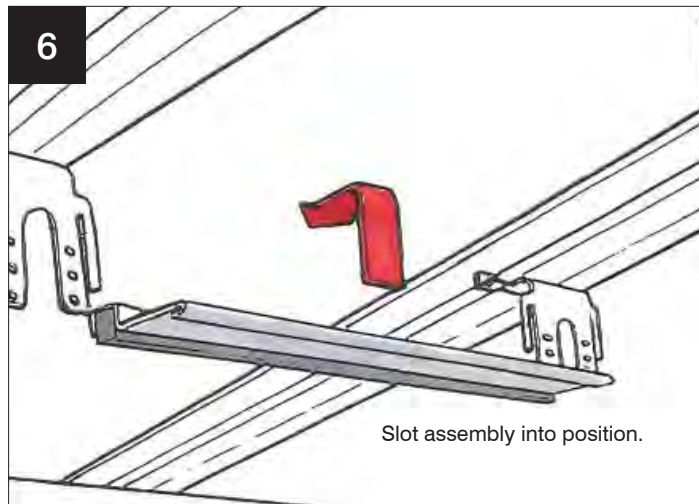

Offer into position the cloaking panel (polycarbonate) support trim – this is lifted up and over the two tabs – one per side of either the transom or Georgian brackets.

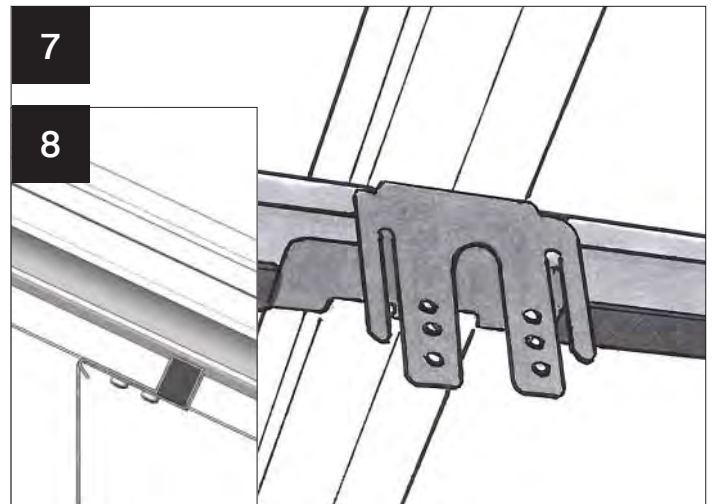

This is what you should see from the underside and the side view.

Now select the cloaking panel (polycarbonate) support trim for the remainder of the positions indicated in steps 5 p34 in red (A, B, C).

INSTALLATION - CLOAKING PANELS - EAVES

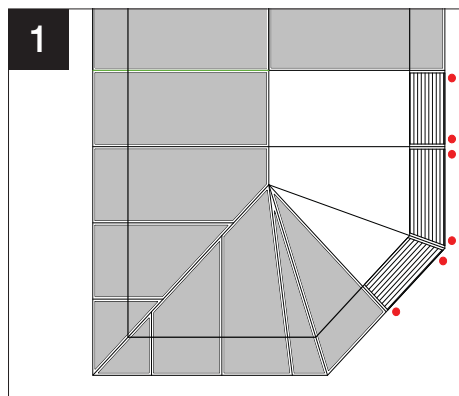

Now it is time to install the polycarbonate cloaking screen panels. See steps 1-7 on this page.

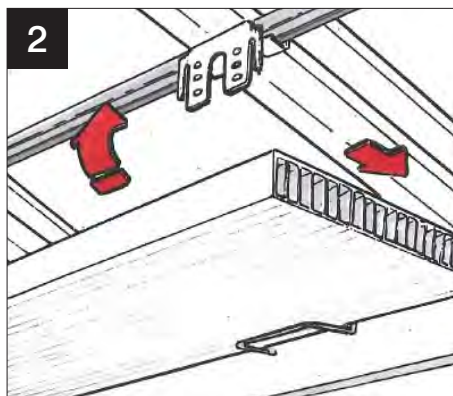

Referring to the location plan, take the appropriate piece of polycarbonate cloaking panel which lays parallel to the eaves. Next, 'sit' it into each of the support clips that are hooked over the fascia. Then push the polycarbonate up into the roof.

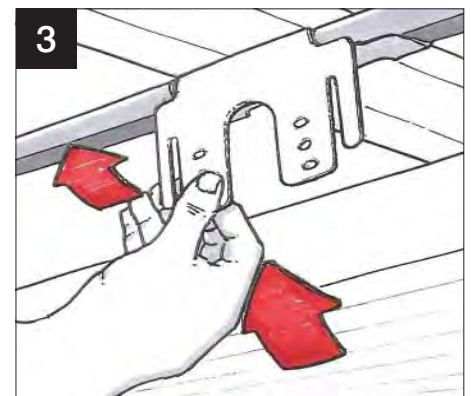

As the polycarbonate is swung into position, the transom brackets may need to be bent slightly backwards to allow the polycarbonate to clear them.

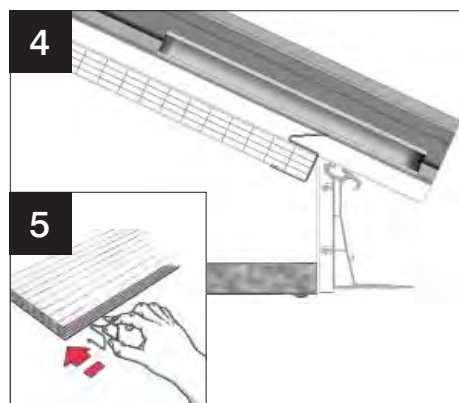

On glazing bars featuring tie bar brackets or those with bolsters, use CHA004 attached to the polycarbonate (acts as a spacer). See step 38 and '•' symbol shows where they are fitted.

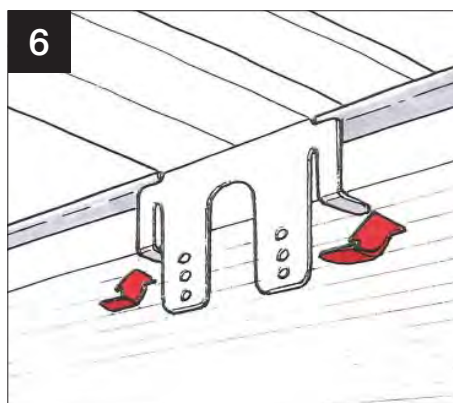

Next bend back the long legged tabs to hold the polycarbonate cloaking trim in its final position.

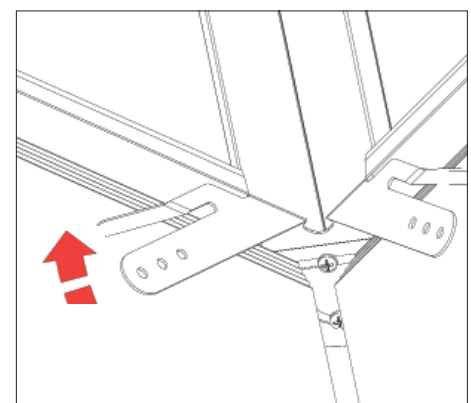

Undertake the same task on the Georgian brackets – ensure the polycarbonate cloaking panel is secured each side of the hip.

INSTALLATION - PELMET LADDERS & 25MM BOARD INSULATION

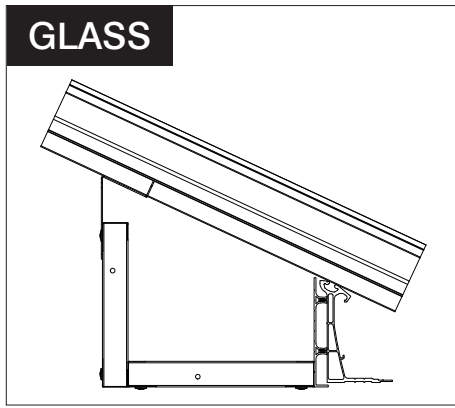

Pelmet position

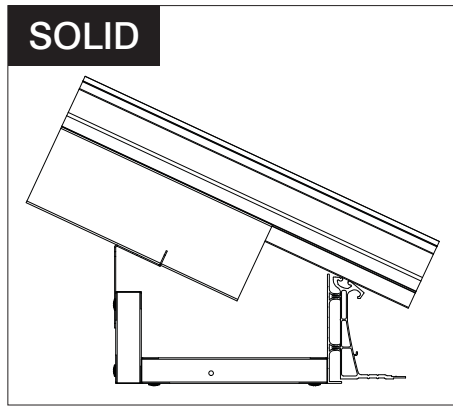

Pelmet position



Assemble matching vertical and horizontal frames - use fixings at 250mm centres into pre-punched holes. Ladders will have different front heights depending whether there is glazing or solid panel.

SEE LOCATION PLAN FOR LADDER LAYOUTS



Attach 'L' shaped frame on fascia or below fascia as location plan dictates.



Undertake a final check that all is plumb, level and true. Three fixing positions are provided, choose appropriate one per bracket leg.



Attach ladders at the corner using 2 x M4 x 13mm fixings per joint.

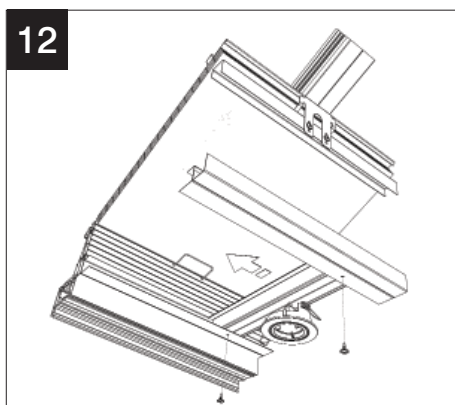

If a spotlight clashes with a cross rail, simply unscrew the cross rail and relocate as close as possible to the original location.

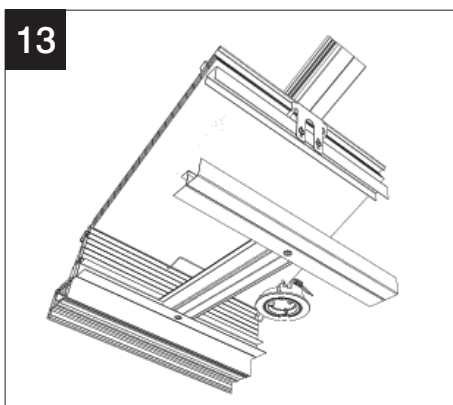

Spot light no longer clashes as horizontal ladder is re-configured on site.



Use mineral wool to close any gaps between 90mm insulation and eaves beam. Reduces condensation risk.

IMPORTANT NOTE: Before applying 12.5mm foil backed plasterboard to ladder framework check lighting positions and adjust horizontal ladders to suit.

INSTALLATION - RIDGE BOARD

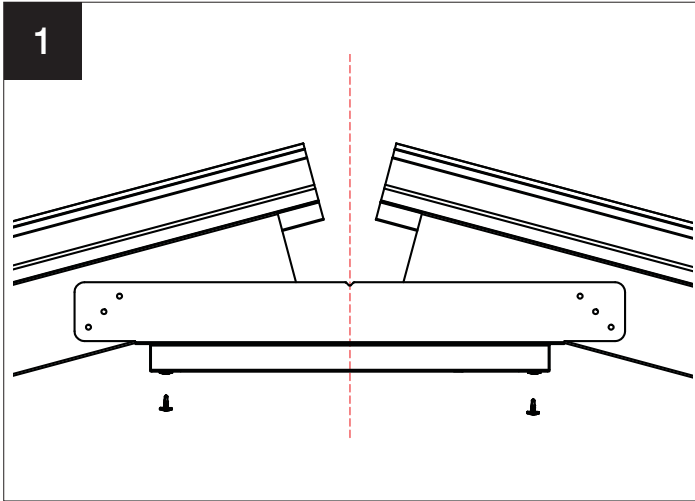

Centre ridge board.

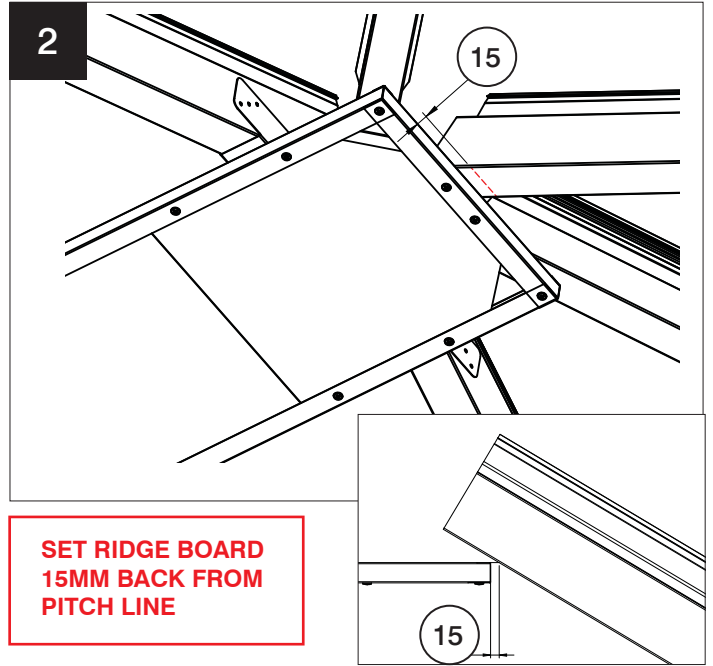

**SET RIDGE BOARD
15MM BACK FROM
PITCH LINE**

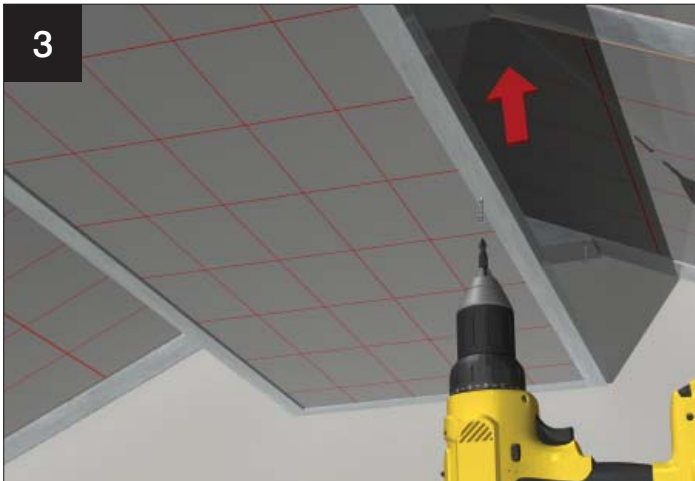

Next take the pre-manufactured ridge board framework – ensure the board sits on the centre line of the ridge - struts. Use drywall screws.
NOTE: ENSURE INSULATION IS FITTED PRIOR TO FIXING RIDGE BOARD

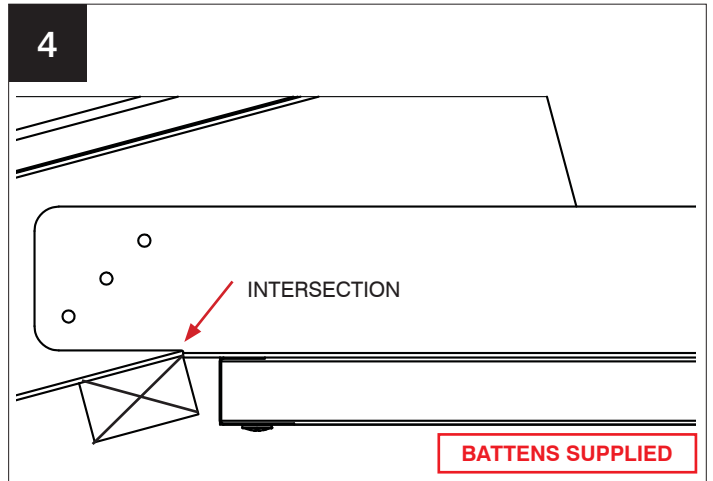

BATTENS SUPPLIED

Next, fit battens around the ridge board. Line 25 X 44 battens with intersection of glazing bar and strut. **GENERAL NOTE: BATTENS ARE FIXED IN POSITIONS WHERE PLASTERBOARD CHANGES DIRECTION, ENABLING SCREWS TO BE FIXED TO THE EDGE OF THE PLASTERBOARD. BATTENS SUPPLIED IN PACKS, NEED TO BE CUT ON SITE TO SUIT.**

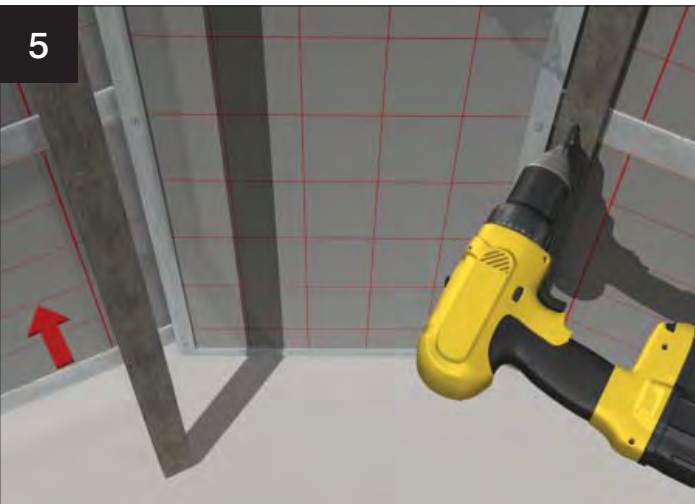

Attach timber battens at every strut position using dry wall screws.
BATTENS SUPPLIED IN PACKS, NEED TO BE CUT ON SITE TO SUIT.



This is how battens should look round Georgian end (top) and Victorian end (bottom).

INSTALLATION - RIDGE - GLAZED PANELS

Product overview, completed ridge with glass panels

NOTE: NOTCHING REQUIRED TO BATTENS AROUND PVCU CLAD BOLSTERS – SEE PAGE 25.

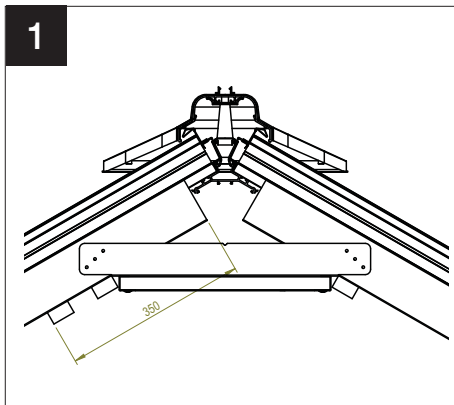
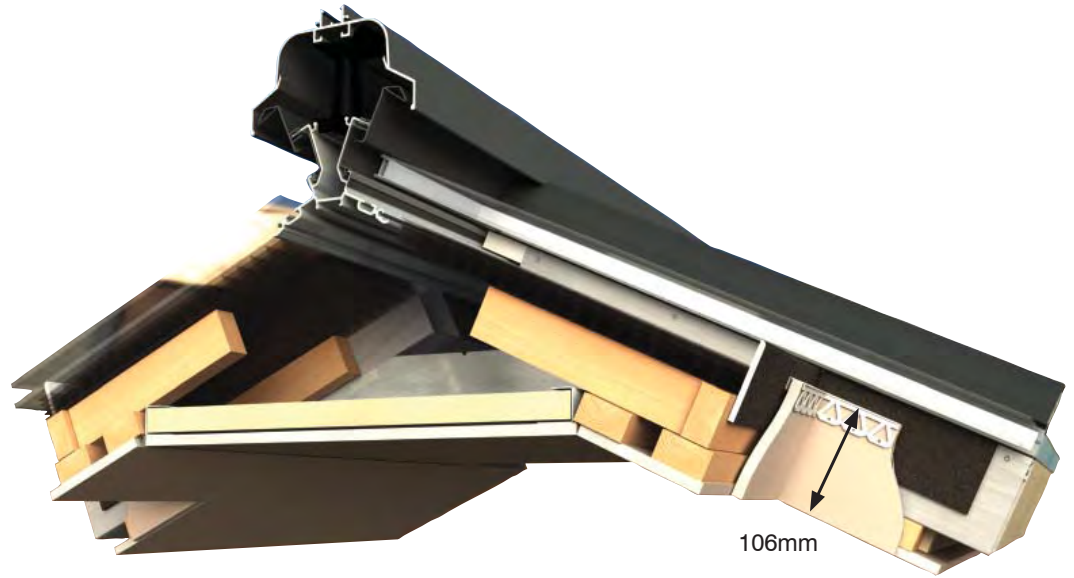

1 On the ridge end – where glazed panels are present – a second row of battens are needed. Measure down from the end of the steel bolster as shown.

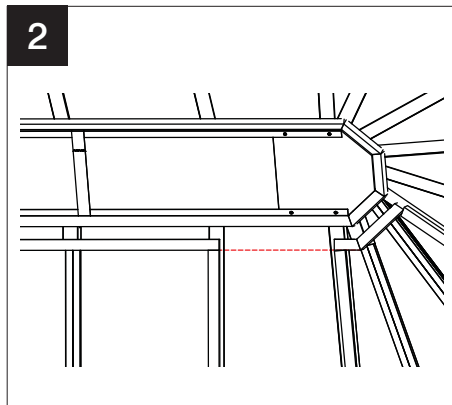

2 Battens around the radius end will line through and remain parallel to the eaves.



3 Use an angle finder to determine angle of each hip bar.

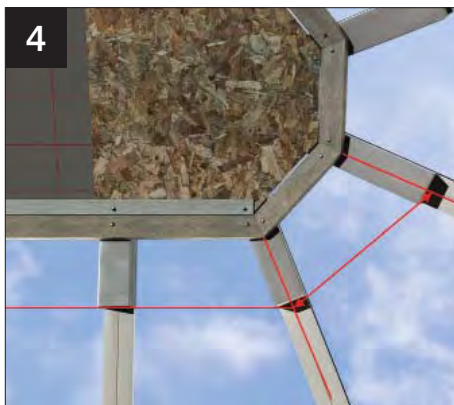

4 Here is the general set out you will be working with (Victorian faceted end illustrated).

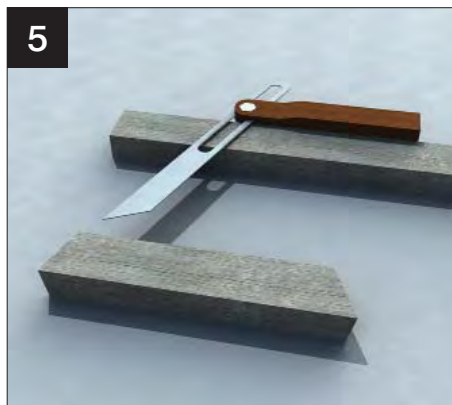

5 Transpose the angle onto the batten and create mitred cuts.



6 Using drywall screws, attach battens into steel bolsters/stub steel bolsters.

INSTALLATION - CLOAKING PANEL RIDGE

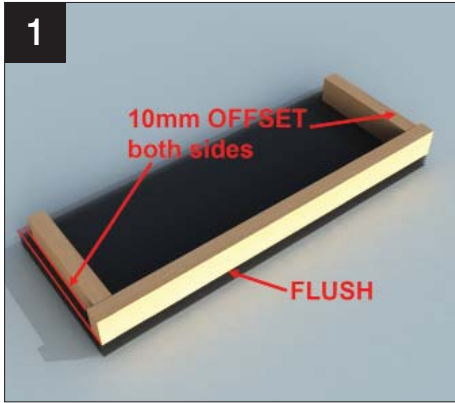

1
ASSEMBLE POLYCARBONATE SCREENS
 Cut 25 X 44 battens and fit using double sided tape (LVGS001). Fit battens flush with front edge and 10mm back on each side.

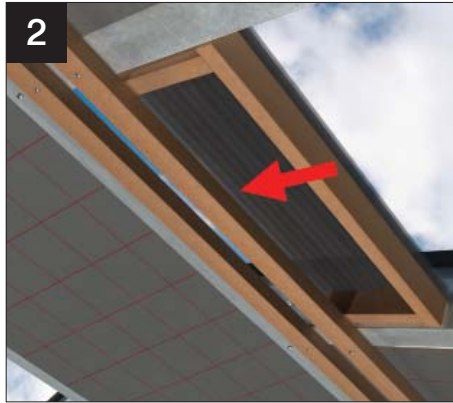

2
 Slot assembly into position.



3
IMPORTANT: POSITION CLOAKING PANEL ASSEMBLY 6MM BACK FROM THE CROSS BATTEN (AS SHOWN) SCREW FIT INTO POSITION.

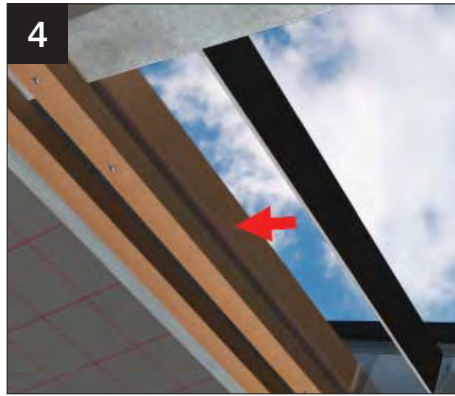
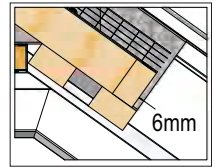

4
 Fit black multiboard and ensure it touches glass. Screw fit using drywall screws) along the lower edge. The multiboard cloaks the side of the steel bolster providing a shadow line. The plasterboard applied to this face finishes 20mm from the glass.



5
 Down each side of glazed area, attach batten, ensure it sits 6mm outboard of bolster (see insert).

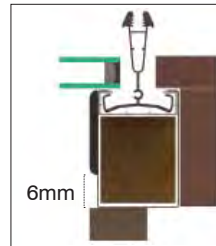

6
 Fit black multiboard - ensure it touches glass. Screw fit.



7
 At eaves attach batten into steel bolsters using dry wall screws.



8
 Next fit the 25mm insulation board, which is 590 x 2400mm. These boards must be laid at right angles to the glazing bars and run across the bars.

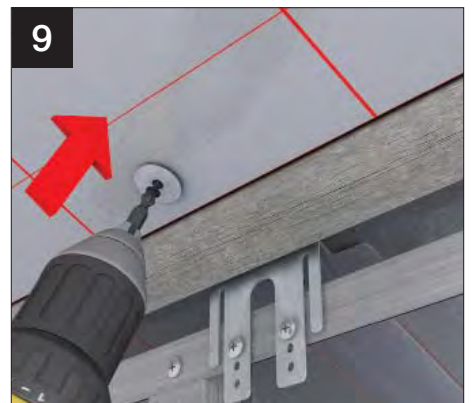

9
 Fasten through the board and into the glazing bars using the drywall screw provided (3.5 x 50mm) and with a washer (kit of 25) behind the head to offer additional support to the board. Use location plan to identify board positions. **Use tape LVFT045 - foil sealing tape - tape ALL joints of 25mm insulation.**

PLASTERBOARDING & PLASTERING

IMPORTANT NOTE: Before applying 12.5mm foil backed plasterboard to ladder framework check lighting positions and adjust horizontal ladders to suit see p36 steps 12 and 13

Guidance is based on advice provided by the SITE BOOK available from www.british-gypsum.com or call 0844 800 1991 bgtechnical.enquiries@bpb.com

This guidance based on the use of Thistle Finishing Plaster and 12.5mm Gyproc Wallboard Duplex T/E which has an additional metalised polyester film to act as a vapour control membrane.

- Based on a 2mm skim finish. Temperature must be maintained above 5deg C until plaster is dry.
- Plaster skimming should always commence as soon as possible after the boards are fixed.
- Use thin wall beads attached with 'dabs' of plaster – to provide additional support during drying, attach with non-rusting nails, screws or staples.
- Reinforce flat joints with Thistle ProTape 50 or FT100 – these are made from glass fibre and are self adhesive and fitted before plastering.
- Any gaps bigger than 3mm must be pre-filled and reinforced using Gyproc Joint Tape which is embedded in the first coat over each joint, where sufficient plaster is left under the tape to ensure good adhesion and then a second plaster application used. This method is better resistance to cracking than glass fibre tapes.
- Apply Thistle Finishing Plaster with firm pressure, build out to 2mm thickness in two applications and then trowel to a smooth finish.

PLASTERBOARDING SEQUENCE

- 1 Underside of pelmet (including mineral wool cavity)
- 2 Flat ceiling
- 3 Sloped ceiling
- 4 Vertical sides of pelmet

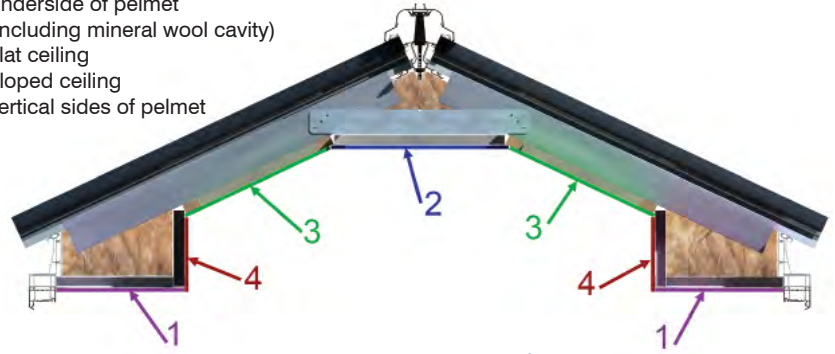

PLASTERBOARDING (DETAILS AROUND THE RIDGE)

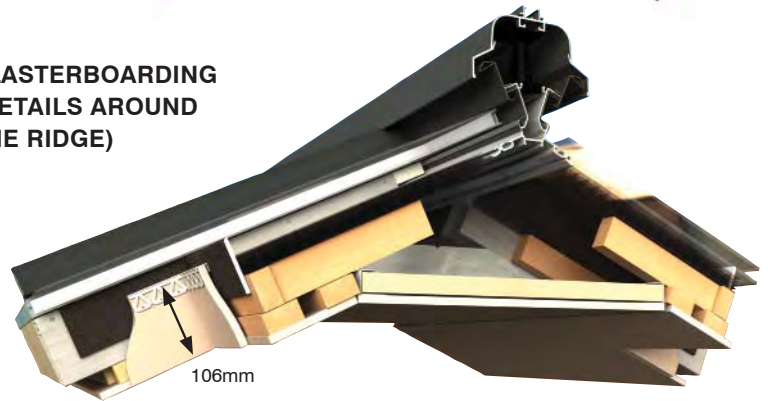

DETAIL FOR CLADDING LIVINROOF HIPs WHICH HAVE A COMBINATION OF GLASS AND SOLID PANELS WITH SOME GLASS UNITS BOTH SIDES OF THE HIP

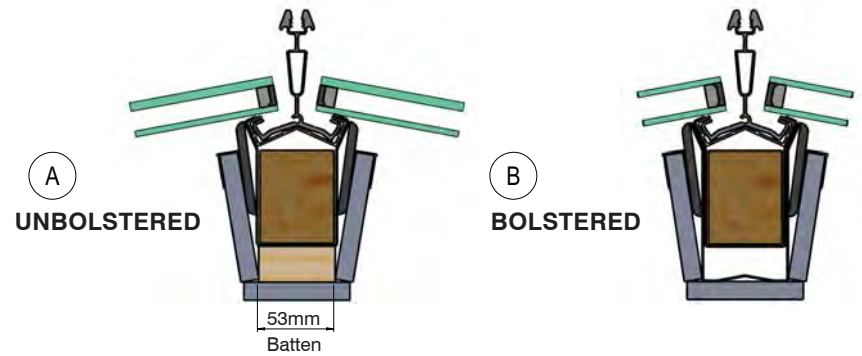

TIE BAR ROSE FINISHING

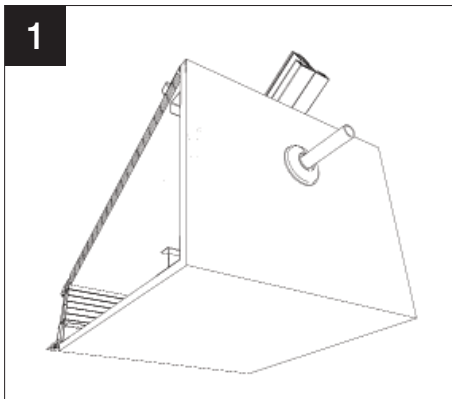

Once 12.5mm plasterboard is fitted, the tie bar rose (CHA005) flexes over the PVCu conduit and should be spot bonded into position.

STOP BEAD ADJACENT TO GLASS PANELS

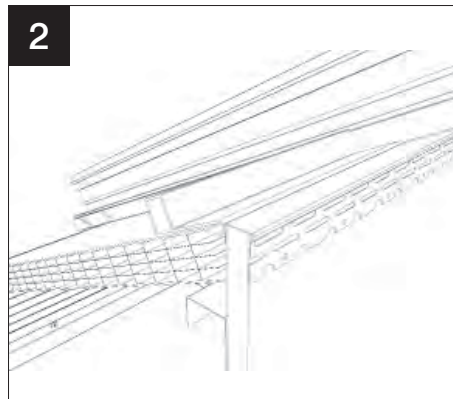

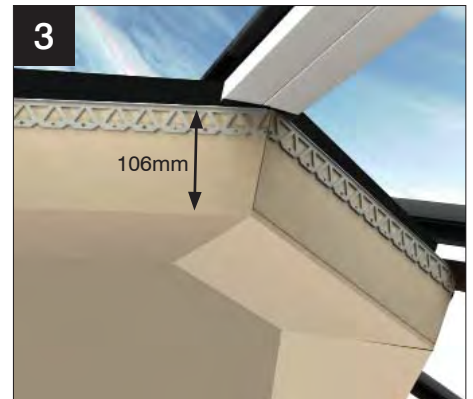

Ultraframe supplies a plasterers stop bead (CHA300) for the top edge adjacent to the glazing – ensure it is attached as shown. Be careful when handling/cutting this item not to damage the paint surface. Plasterboard finishes 20mm away from the glass.



Ridge end detailing

APPENDIX 1 - TIE BARS

 DENOTES SOLID PANEL
 DENOTES GLAZED PANEL

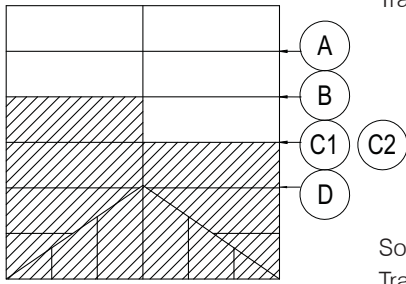

Glass - glass
Traditional Tie bar

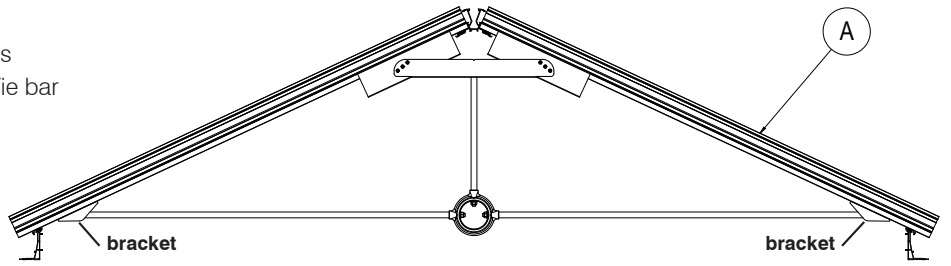

Solid - glass
Traditional Tie bar

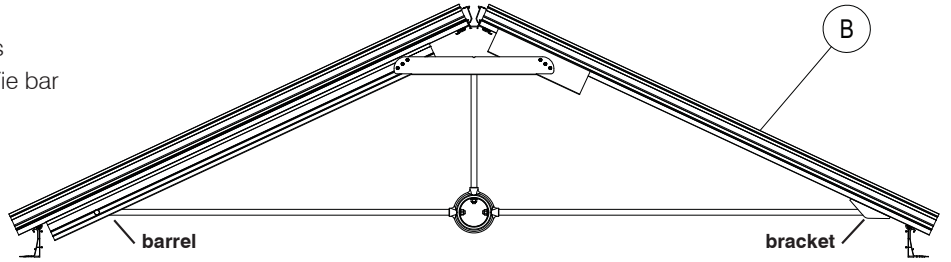

Solid - solid
Traditional Tie bar

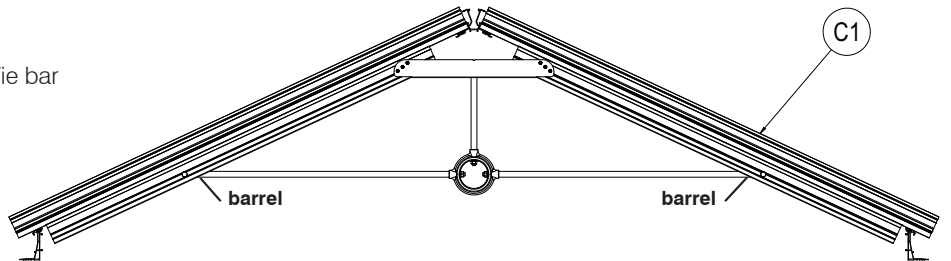

(D) Solid - solid and (C2) solid - glass
(Standard Option) Tie beam

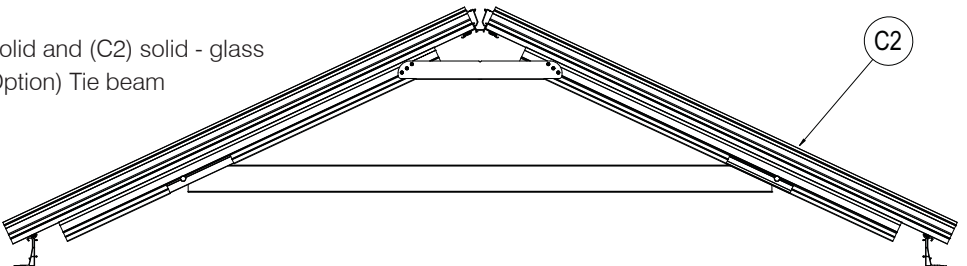

APPENDIX 1 - INSTALLATION - FIT TIE BARS - TRADITIONAL TIE BAR

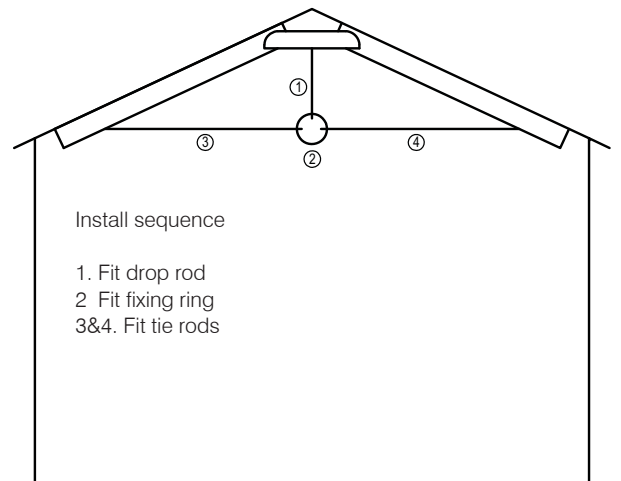
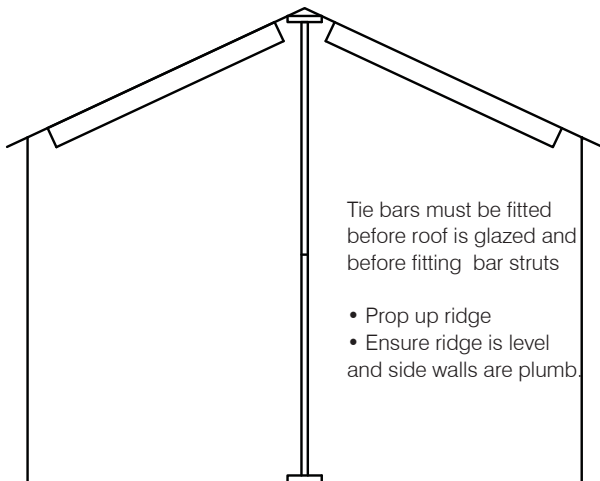

APPENDIX 1 - FITTING - TRADITIONAL TIE BAR



1
Insert threaded drop rod into pre-prepared hole in relevant strut. The vertical bar is secured to the strut.



2
Insert the smaller diameter pieces of PVCu conduit inside. Offer into the boss ring and finger tighten the nyloc nut.

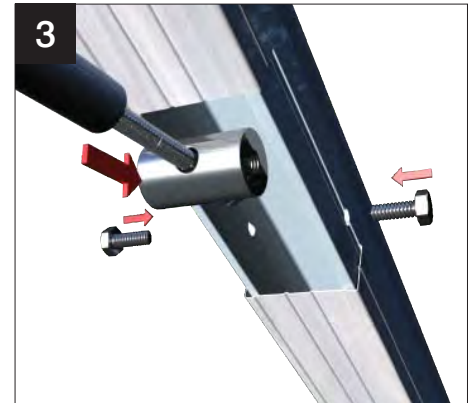

3
If the tie bar is attached with a barrel, insert pre-assembled barrel (see steps 1, p44) into glazing bar slot, line up holes and secure with 2 x M10 bolts. If tie bars are attached with traditional brackets see 'A, B, C' below.

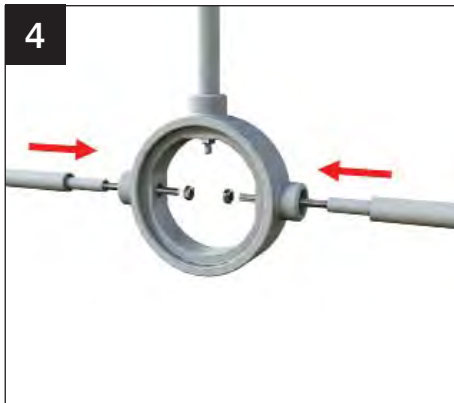

4
Insert threaded bar into the ring, and again finger tighten the nyloc nuts.

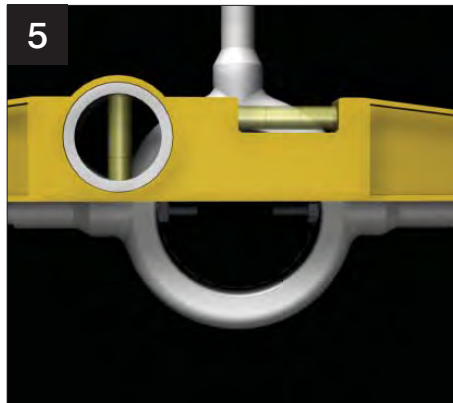

5
Now, finally check that the horizontal elements are level and the vertical element is plumb. CHECK THAT THE SIDE FRAMES ARE STILL PLUMB. Spanner tighten the boss nyloc nuts.

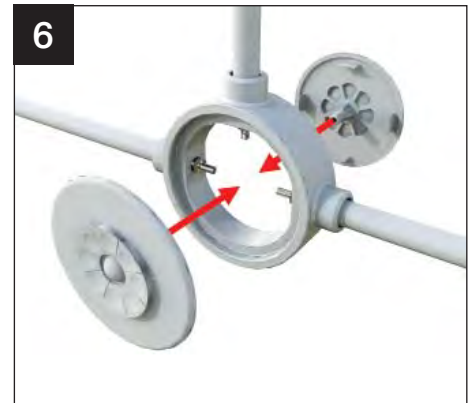

6
Offer up the two part rose cover, spin one half onto the threaded end of the other half.

TIE BAR FOR GLAZING OR MIXED PANELS



A
Measure, cut and attach the horizontal threaded bars (ensure sufficient engagement of the bar into the brackets) – it is essential that the tie bar boss is central. Take the boss ring, and loosely assemble the threaded bars to check they terminate inside the ring. Dis-assemble.

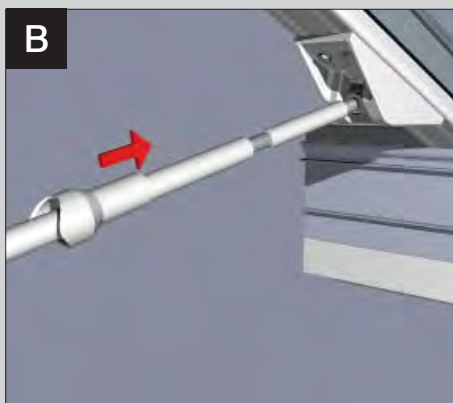

B
Offer up the horizontal pieces of PVCu conduit (large and small diameter) and include a rose cover.

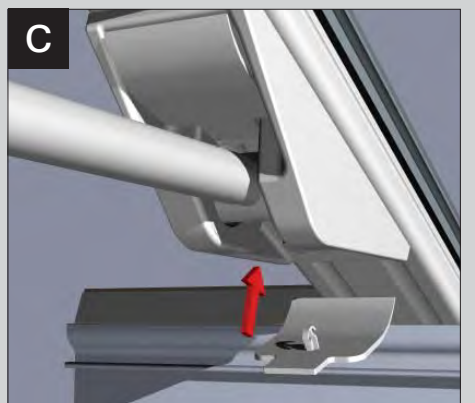

C
Attach the bracket cover plates that hide the bolts.

APPENDIX 1 - FITTING TIE BEAM

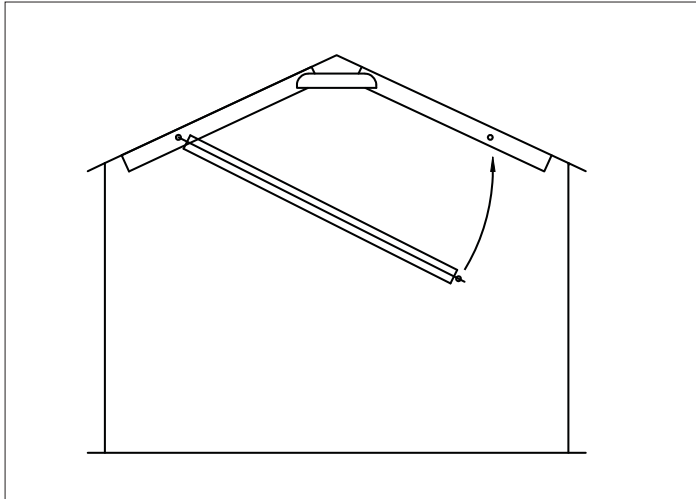

Overview

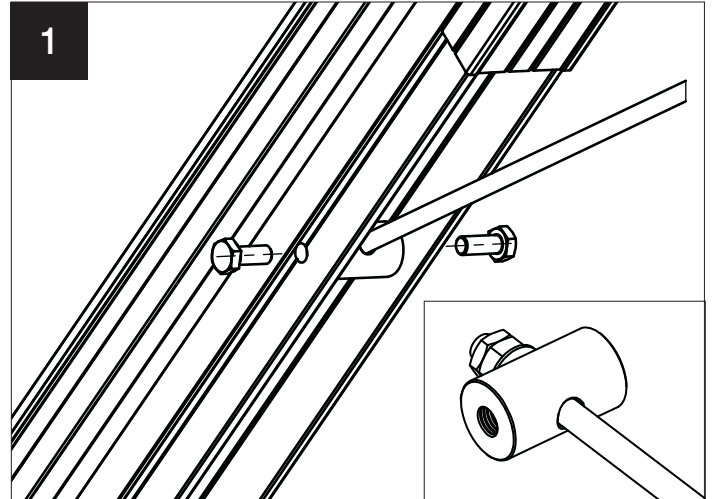

Attach the threaded bar through the barrel and then fit washer and two M10 nuts. Next insert the barrel assembly into the slot in the underside of the glazing bar and secure with a further two M10 nuts.

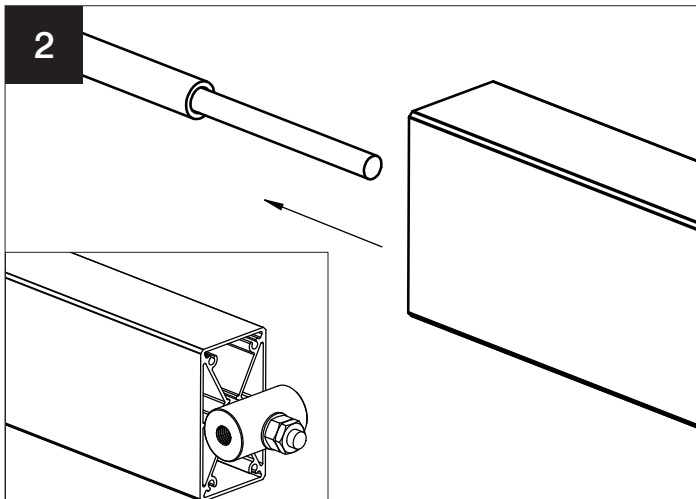

Now insert the PVCu tube (this acts as a damper) over the threaded bar and secure in place with double sided tape or silicone. Now insert the box section beam over the threaded bar/tube assembly.

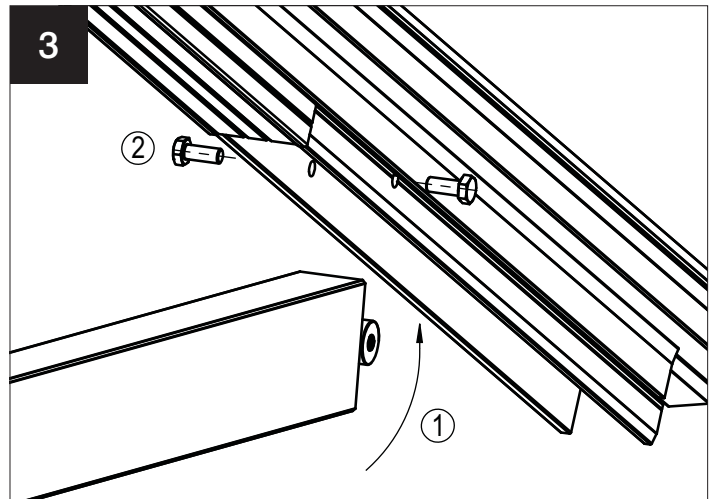

Now at the other end of the beam, add PVCu tube and the second barrel and repeat step 1. Swing the beam into position (as the overview at the start of this section). Adjust the threaded bar to length and then secure the barrel with 2 M10 bolts.

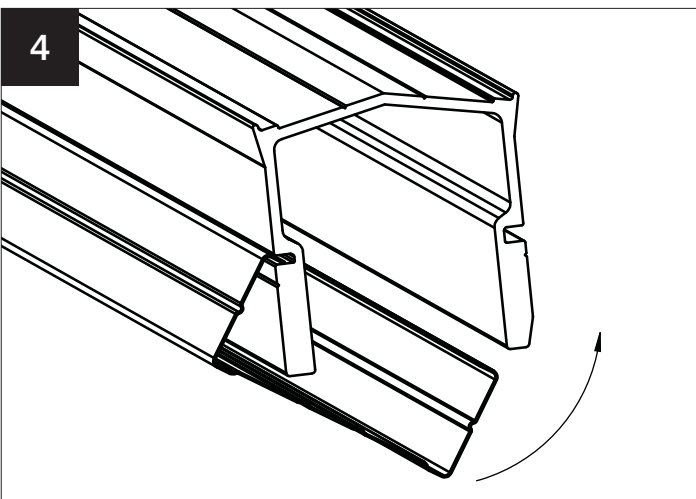

Now is the time to fit the claddings.

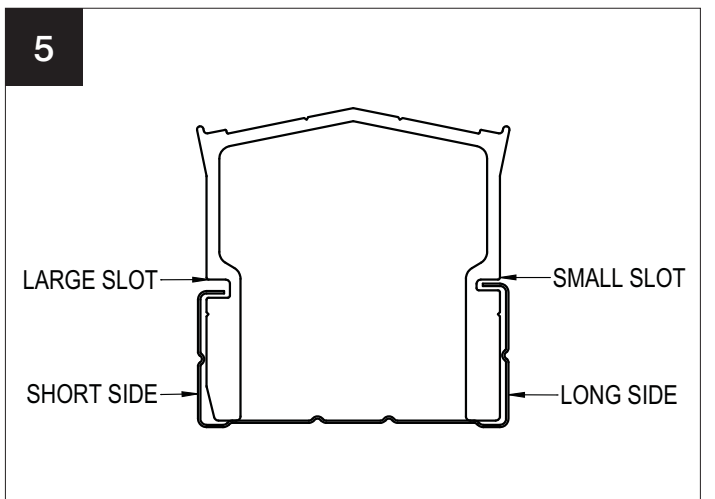

Ensure the asymmetric cladding is attached as shown – short side mates with the large slot whilst the long side mates with the small slot.

APPENDIX 2 - BOLSTER BARS - GLASS BOTH SIDES

1

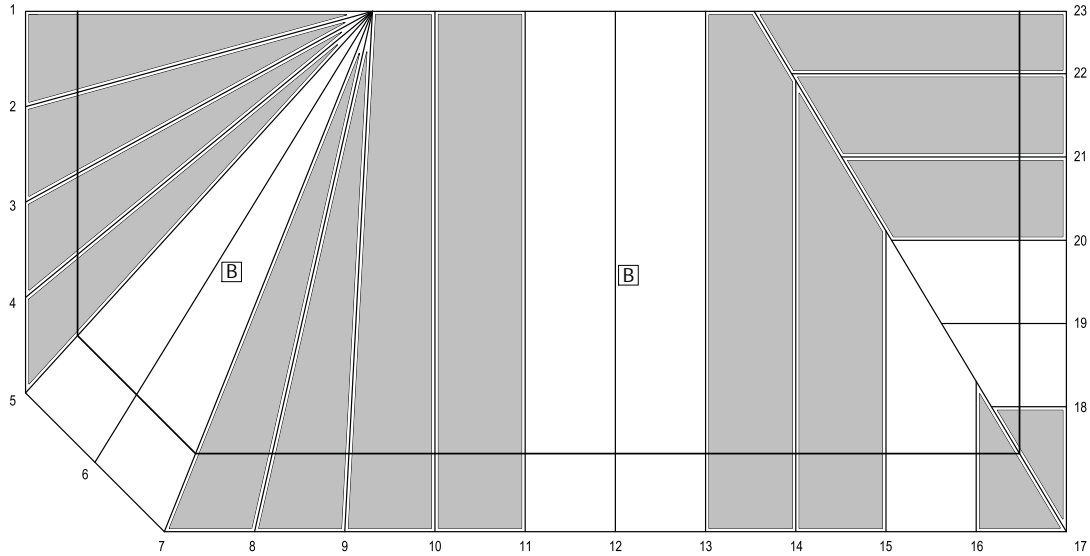

PREFIX S: SOLID PANEL
PREFIX G: GLASS PANEL

USE THE LOCATION PLAN TO FIND THE BOLSTER BAR LOCATION DETAILS

2

STANDARD BRACKET BAR POSITION(s)	CHA001 (mm)	CHA003 (mm)	CHA090 (mm)	CHA011 (mm)	CHAA019L (mm)	CHAA019R (mm)
1	S-200					
2				G-207L/221R		
3				S-229L/256R		
4				G-264L/304R		
5	S-142	G-324L/357R			G-429	S-1822
6				G-418		
7	G-248	G-370L/371R				G-403
8	S-142			G-329L/335R		
9				G-329L/326R		
10, 14	G-325					
11, 15	G-325				G-349	
13, 16	G-325					G-349
17			G-276L/239R			
18	S-160				S-203	
19	G-279					
20	S-160					S-203
21 - 23	S-160					
BOLSTER BRACKET BAR POSITION(s)	CHA009 (mm)	CHA012 (mm)	CHA013L (mm)	CHA011 (mm)	CHA013R (mm)	
12	G-424					

3

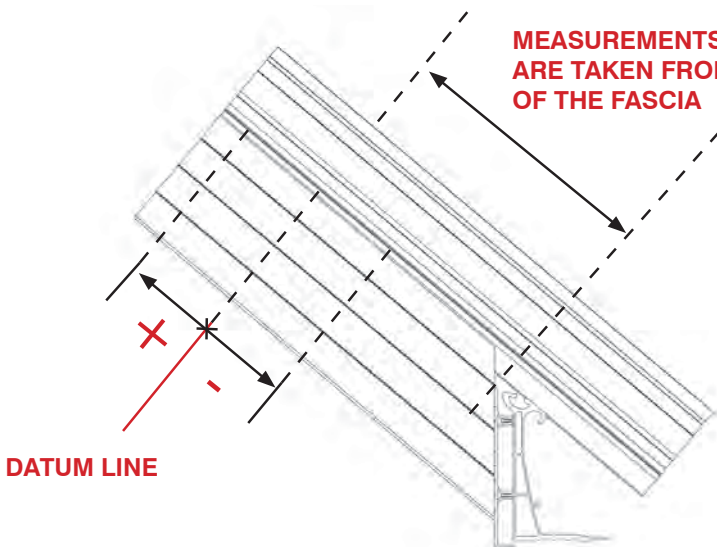

MEASUREMENTS FROM EAVES ARE TAKEN FROM THE TOP EDGE OF THE FASCIA

NOTE:
 '+' Dimension towards ridge
 '-' Dimension towards eaves

APPENDIX 2 - BOLSTER BARS - GLASS BOTH SIDES - TRANSOMS

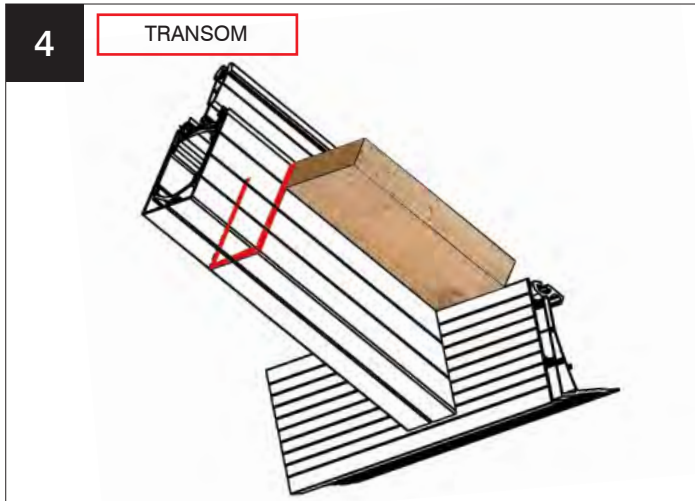

Using the location plan provided – see example in fig 1 - find the dimension for setting out bracket positions on the transom bars. Measure up the bar from the eaves beam, and mark the bolster cladding on all three sides. If your roof features many transom bars, it may be simpler to cut a piece of timber to length, to use as a template and mark using that.

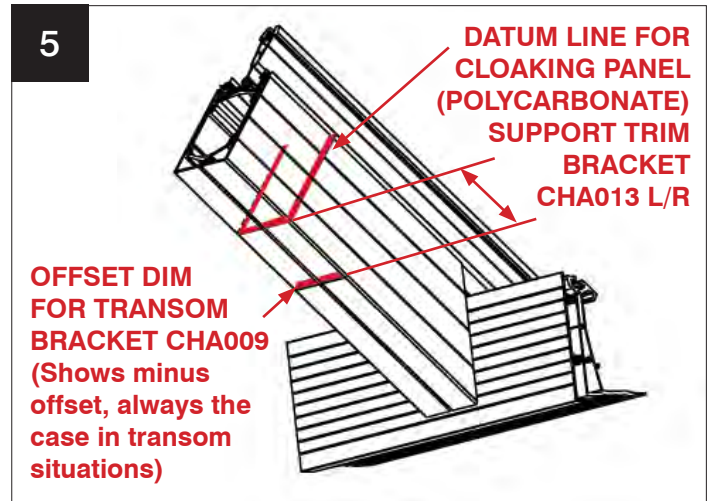

Using the bolster set out data on the location plan, mark each of the transom bars, for the bottom bracket using the offset dimension, always measuring down towards the eaves in transom situations.

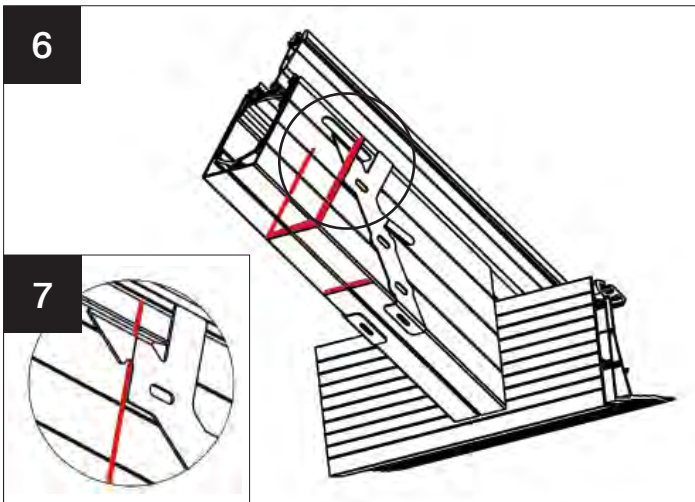

Take the bracket CHA013 L or R (fig 7) and line up with datum line (see inset diagram)

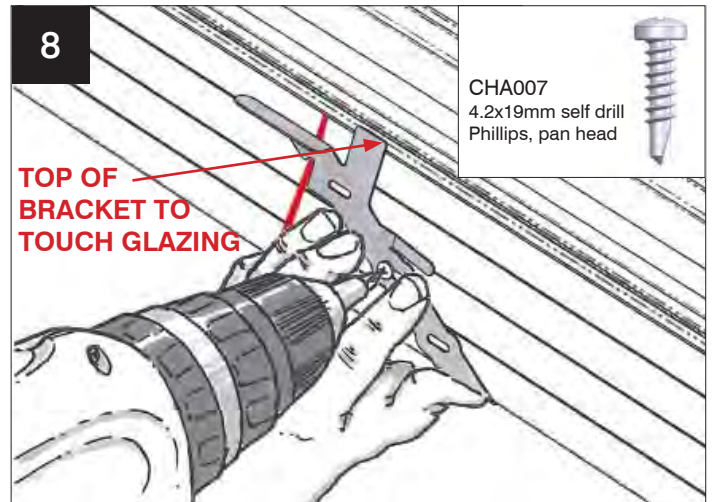

Now attach the bracket with a minimum of two CHA007 4.2 x 19mm self drill panhead Phillips screws. Repeat the process for the L (left) side bracket.

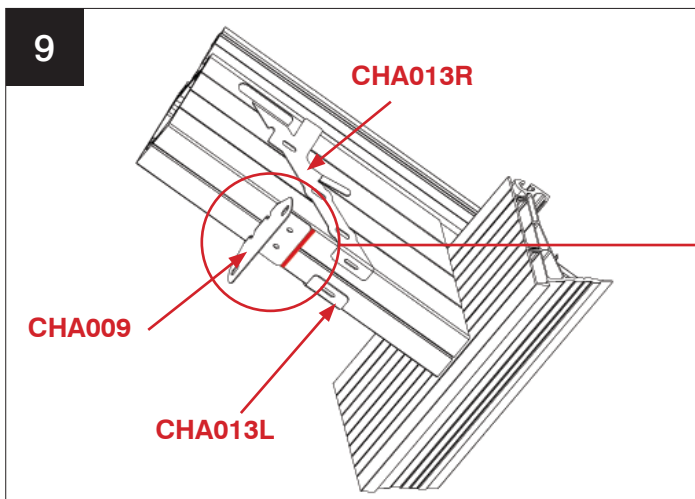

Then take the CHA009 transom bracket and line it through with the pre-marked minus offset dimension – see illustration alongside. Fasten with two CHA008 4.8 x 32mm self drill panhead Phillips screws.

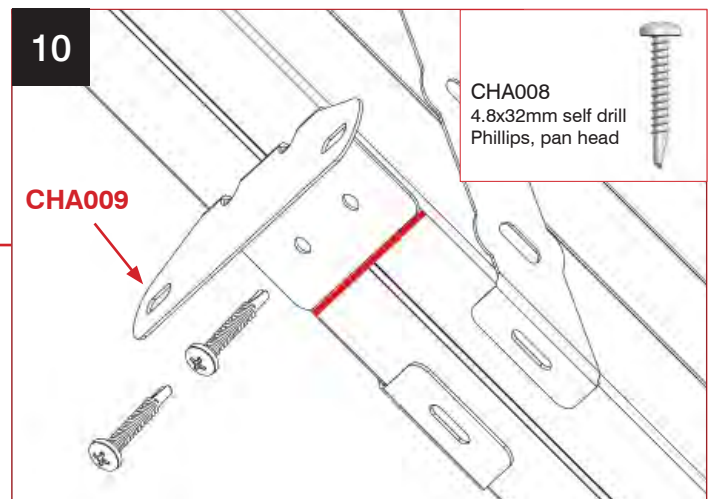

APPENDIX 2 - BOLSTER BARS - GLASS BOTH SIDES - HIPS

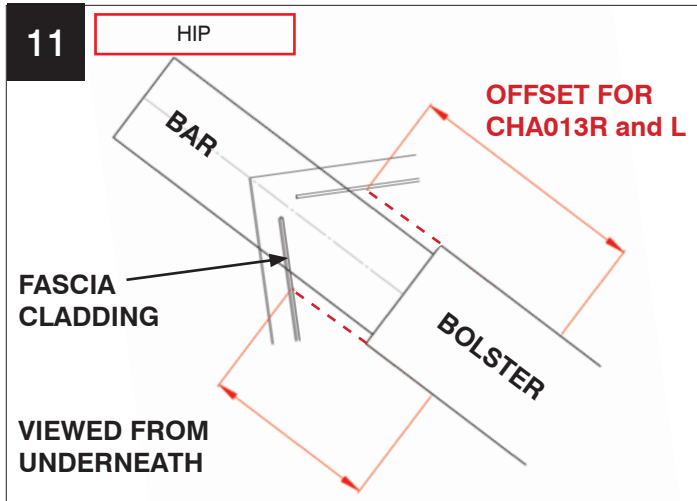

Looking from underneath the bolstered Georgian hip bar, strike a line down the side of the bolster cladding and put a datum line on top of the fascia.

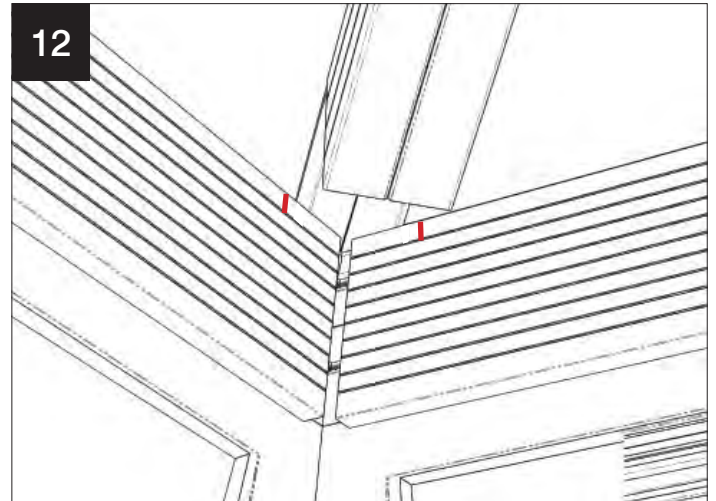

This is how it should look when you have marked each side of the eaves fascia with a datum point to measure from.

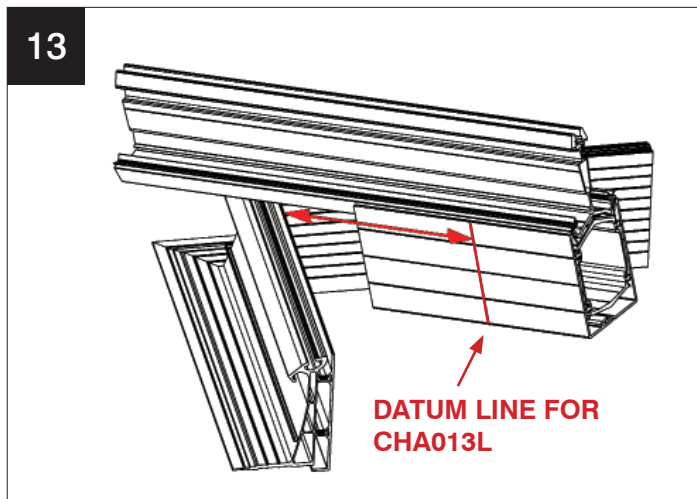

Now referring to the location plan, check the dimensions for left and right. Measure up the bar from the datum mark and mark both the side and face of the bolster cladding from the datum mark. Complete the task on left and right sides – the dimension may be different for each side.

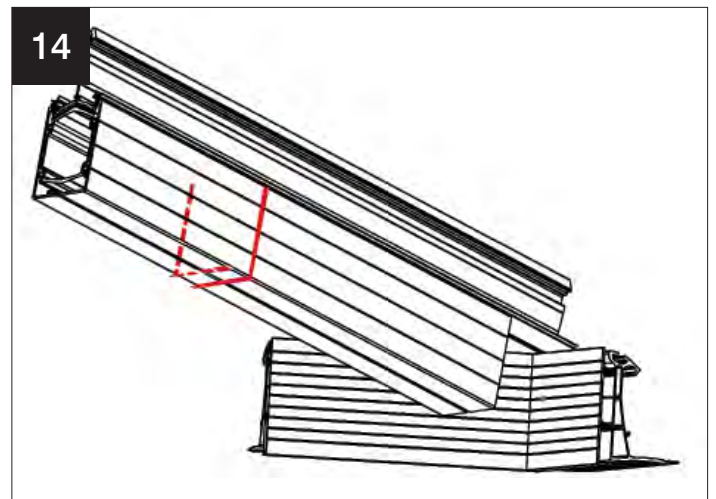

This is how it should look once you have measured and marked the hip bolster cladding.

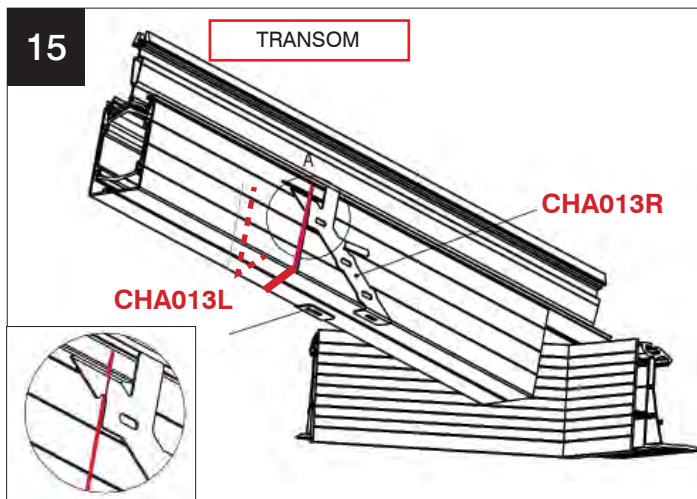

Take the bracket CHA013 L or R (right hand illustrated) and line up with datum line (see inset diagram).

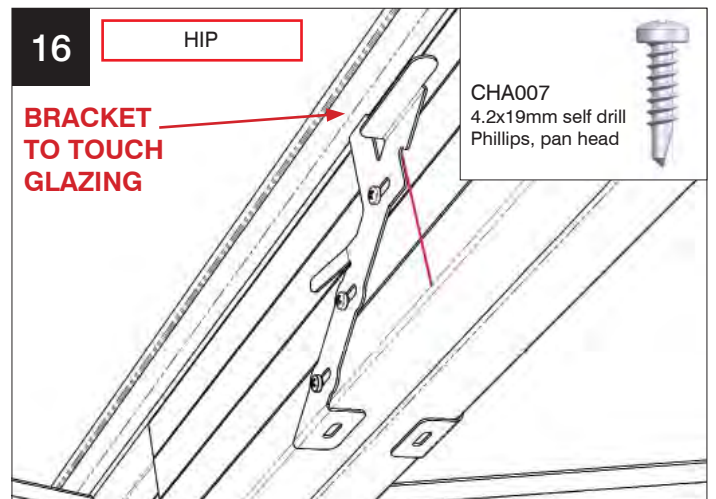

Now attach the bracket with a minimum of two CHA007 4.2 x 19 mm self drill panhead Phillips screws. Repeat the process for the opposite hand bracket.

APPENDIX 2 - BOLSTER BARS - GLASS BOTH SIDES - SPLAYED

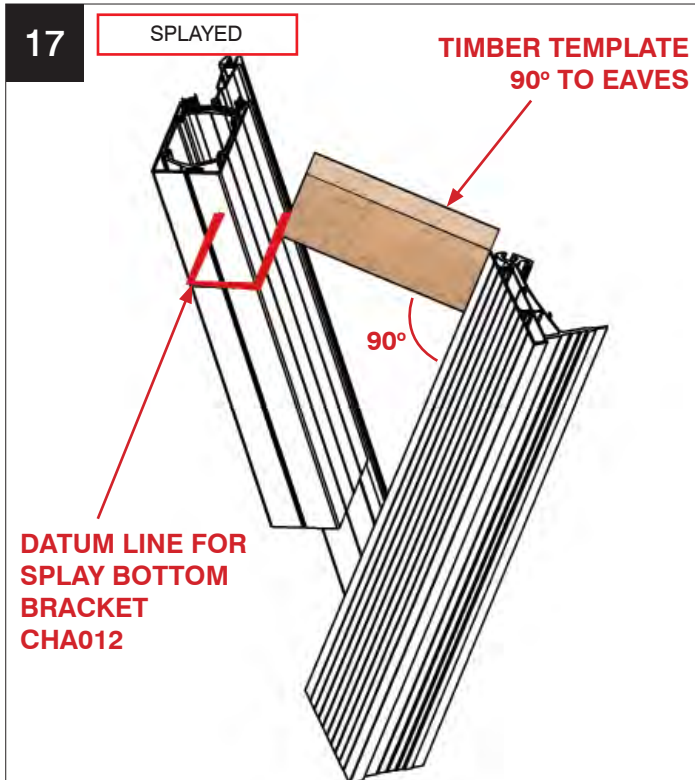

From the location plan, find the dimension for the splayed bar and cut a piece of timber to that length. Hold the timber along the top edge of the PFTB fascia board and then against the glazing. Mark a line all the way round the splayed bar cladding.

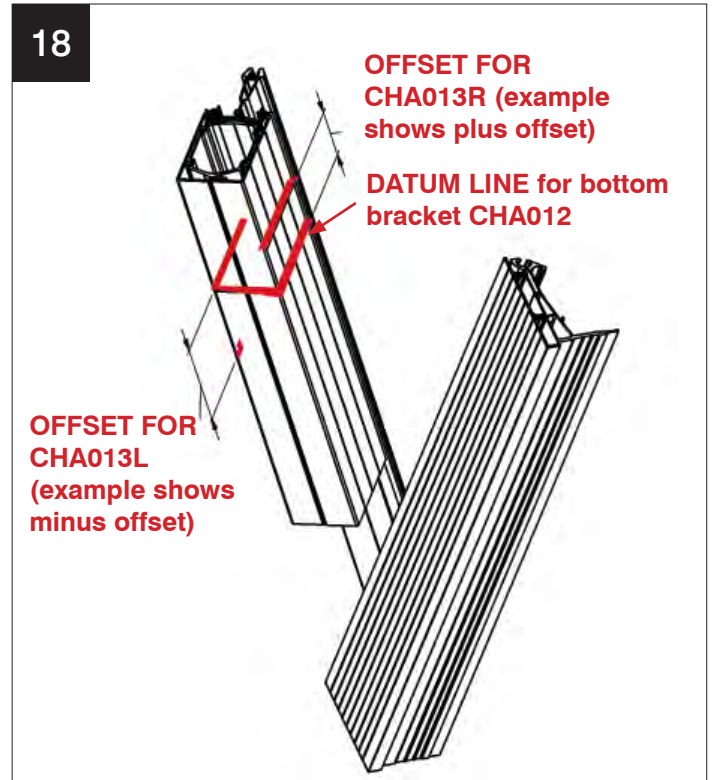

Using the location plan, measure and mark either the positive offset or the minus offset.

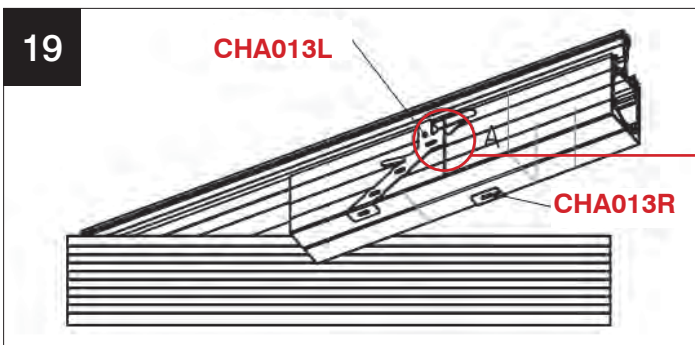

Take the bracket CHA013 L or R and line up with offset line. Now attach the bracket with a minimum of two CHA007 4.2 x 19mm self drill panhead Phillips screws. Repeat the process for the opposite hand bracket.

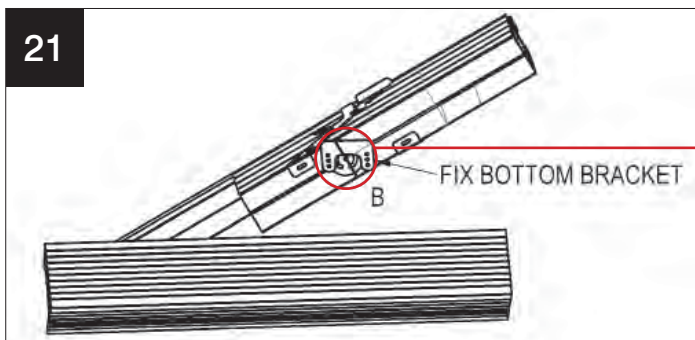
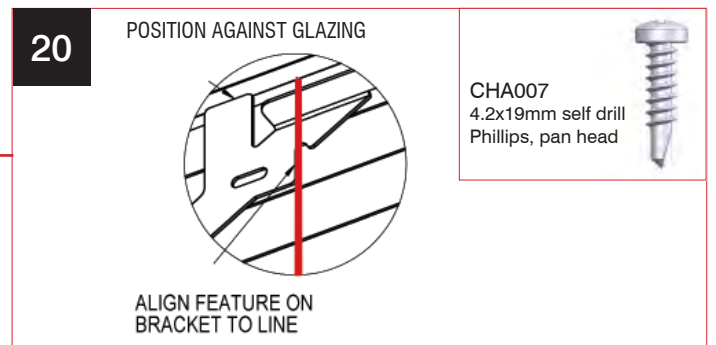

Then take the CHA012 splay bar bracket and line it up with the datum line – see illustration alongside. Fasten through centre hole with one CHA008 4.8 x 32mm self drill panhead Phillips screw.

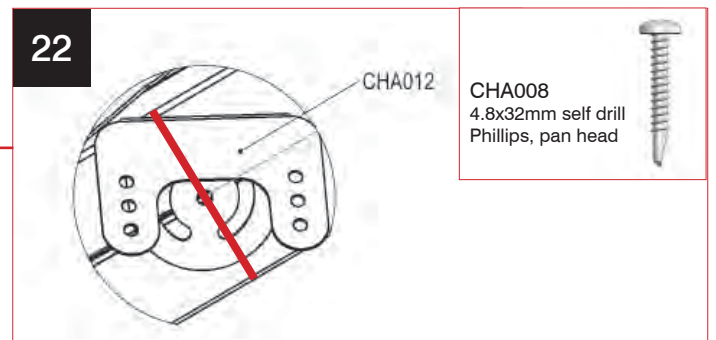

APPENDIX 2 - BOLSTER BARS - GLASS BOTH SIDES

23

**CHA002
CLOAKING
PANEL
SUPPORT
CLIPS**

**CHA002
CLOAKING
PANEL
SUPPORT
TRIM**

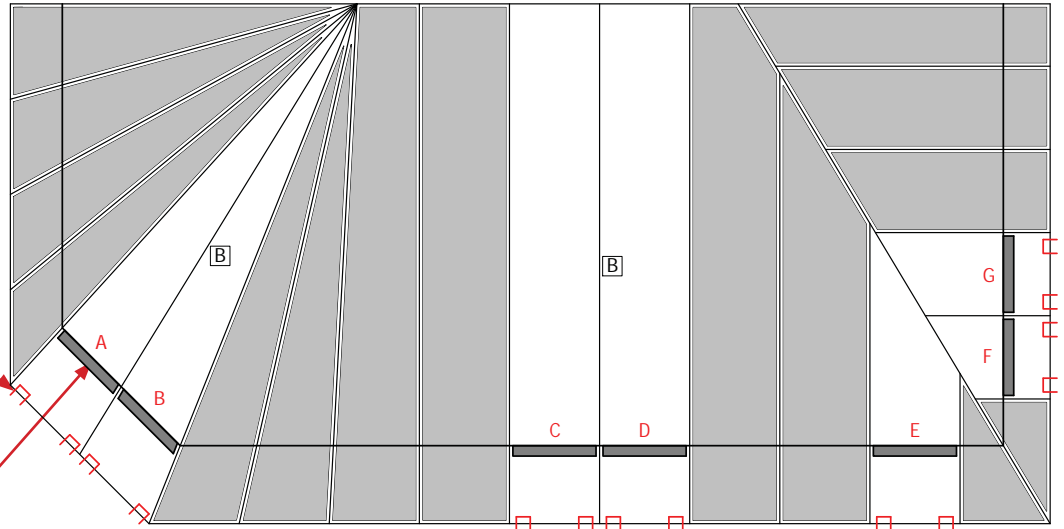

THE LOCATION PLAN SHOWS THE POSITIONS OF THE CLOAKING PANEL (POLYCARBONATE) SUPPORT CLIPS AND THE CLOAKING PANEL SUPPORT TRIMS.

24

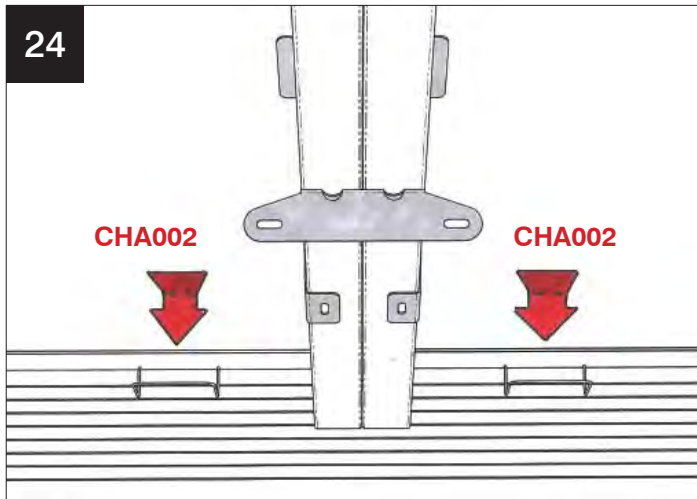

A cloaking panel (polycarbonate) support clip is placed each side of the transom bolster bars.

25

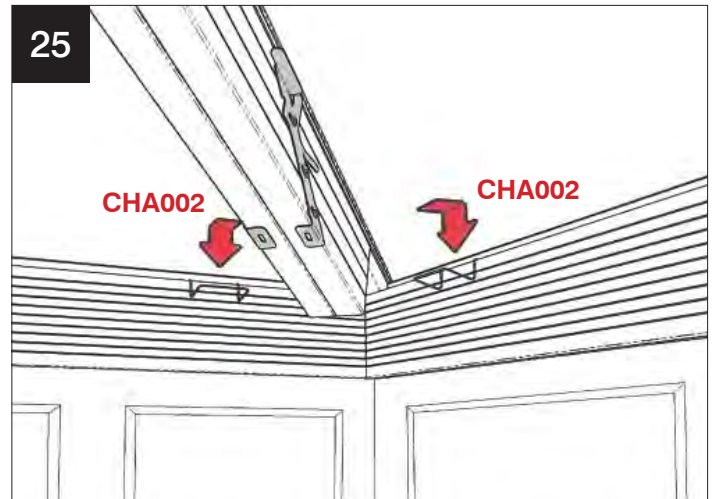

The support clips are located over the PFTB fascia board at hips and splayed bar positions too.

26

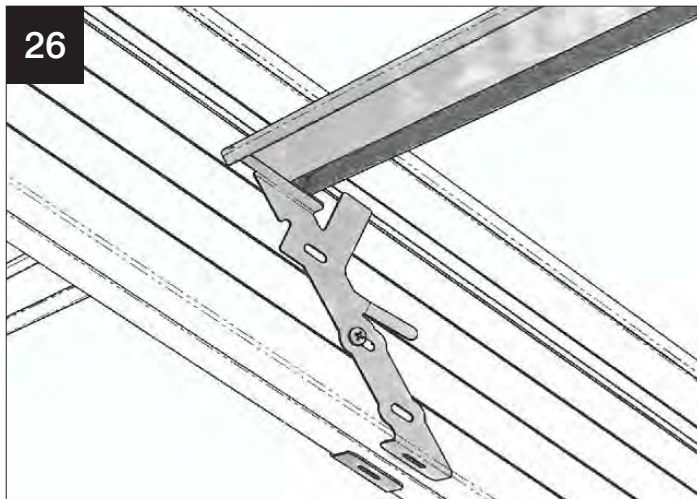

Offer into position the cloaking panel (polycarbonate) support trim – this is lifted up and over CHA013.

27

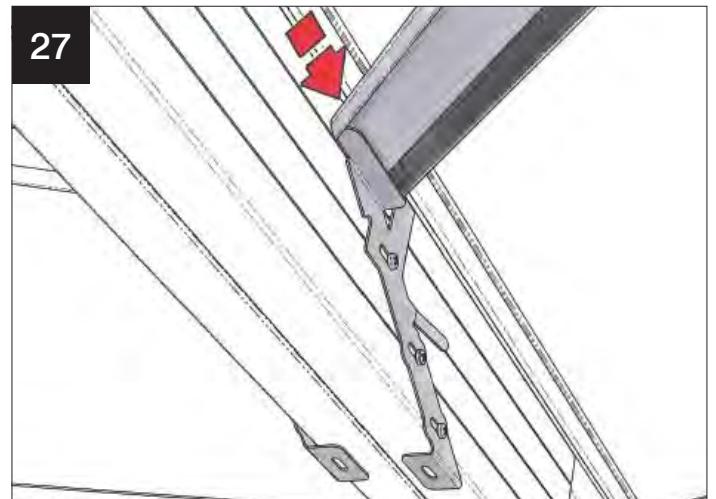

The cloaking panel support trim locks into position.

APPENDIX 2 - BOLSTER BARS - GLASS BOTH SIDES

28

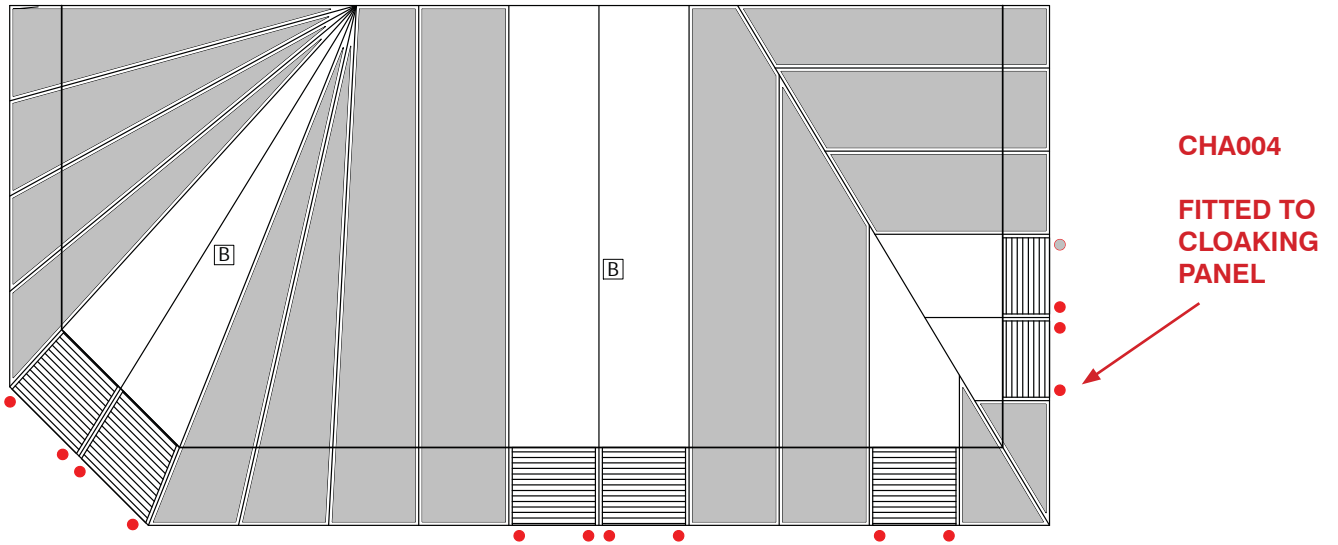

NOW IS THE TIME TO INSTALL THE POLYCARBONATE CLOAKING SCREEN PANELS – SEE LOCATION PLAN TO FIND THE PANELS YOU NEED.

29

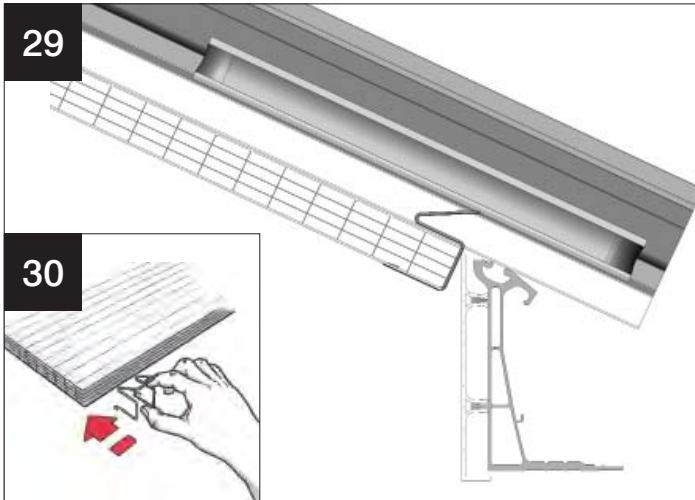

Now attach these polycarbonate support spacers CHA004 – attach to the leading edge of the polycarbonate (silver side up). Location plan and '●' symbol shows where they are fitted.

31

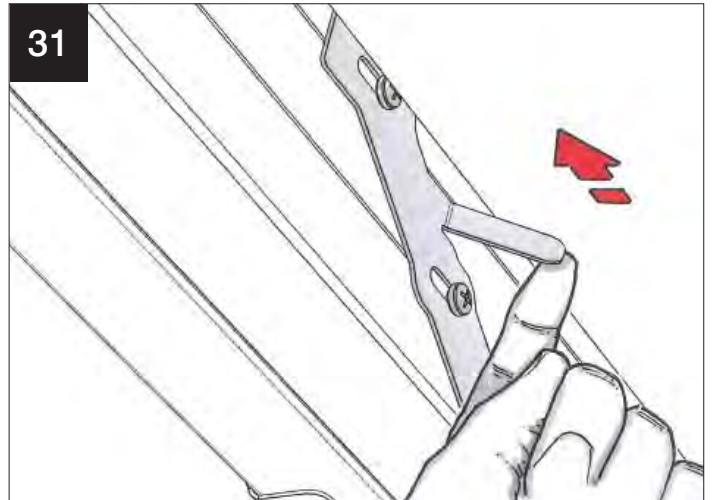

Fit the cloaking panel (silver side up) between the bolsters supported at the eaves by the support clips CHA002. Next bend back the long legged tabs on the CHA013 to hold the polycarbonate cloaking trim in its final position.

32

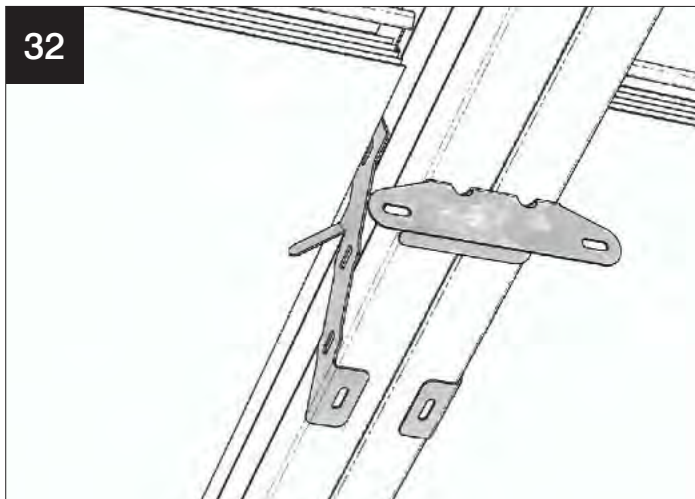

This is how the transom bolster bar should look at this stage.

33

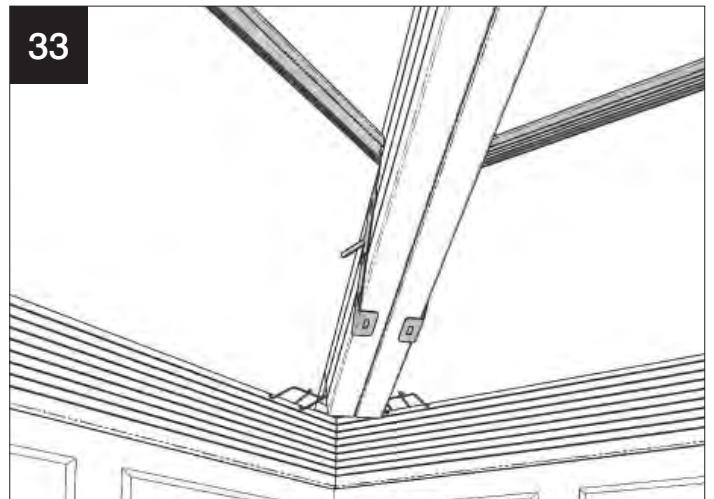

And this is how the Georgian bolster bar should look too.

APPENDIX 2 - BOLSTER BARS - GLASS BOTH SIDES

34

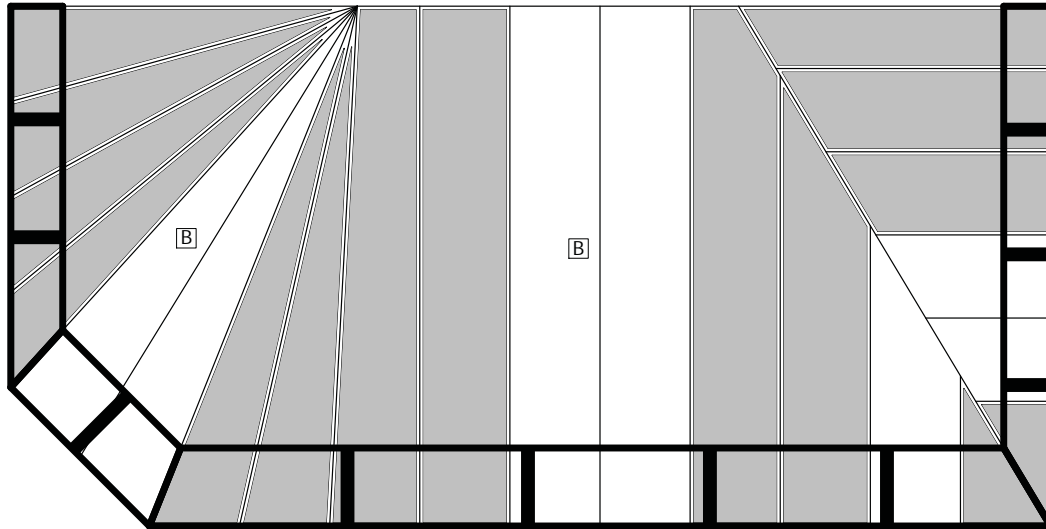

IMPORTANT NOTE. NOW CHECK ON THE LOCATION PLAN WHETHER THE HORIZONTAL FRAME IS FOR 'ON FASCIA' FIXING OR 'BELOW FASCIA' FIXING – SEE MAIN GUIDE PAGE 37, STEPS 2 AND 3.

35

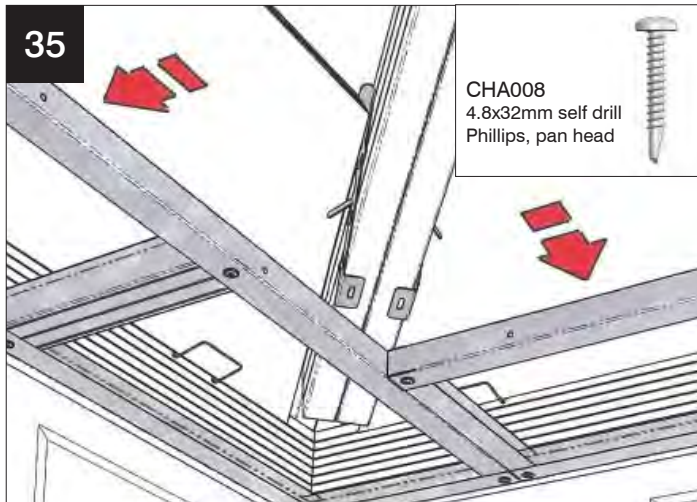

Having referred to the location plan, offer up the first horizontal ladder – a temporary timber support leg will help you here. Use 4.8 x 32mm at 250mm centres into pre punched holes to attach the ladder. Connect horizontal ladders together using two CHA006 fixings. Add adjacent horizontal ladders.

36

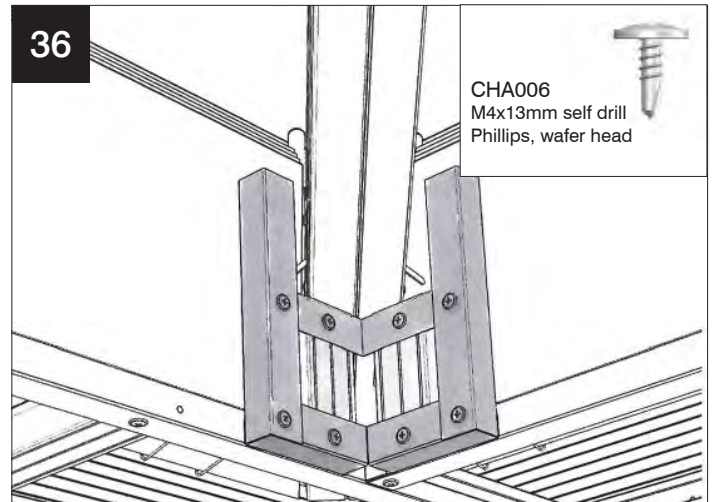

Unpack the bolster corner infill – it is supplied flat and needs to be unpacked and folded into a right angle. Taped to it are two 100mm fixing channels – place these on one side for later. Offer up the corner infill and screw through horizontal ladder into the back of the corner infill – use two CHA006 M4 x 13mm self drill wafer head Phillips screws per side of the corner.

37

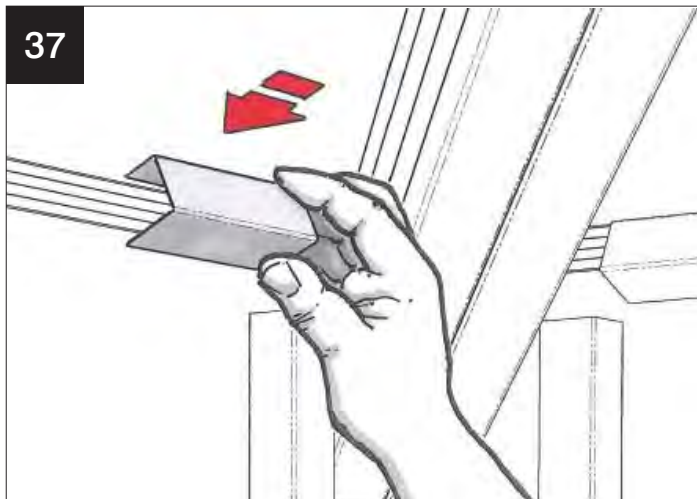

Now take the two 100mm pieces of fixing channels and slip over the two polycarbonate panels adjacent to the hip bar.

38

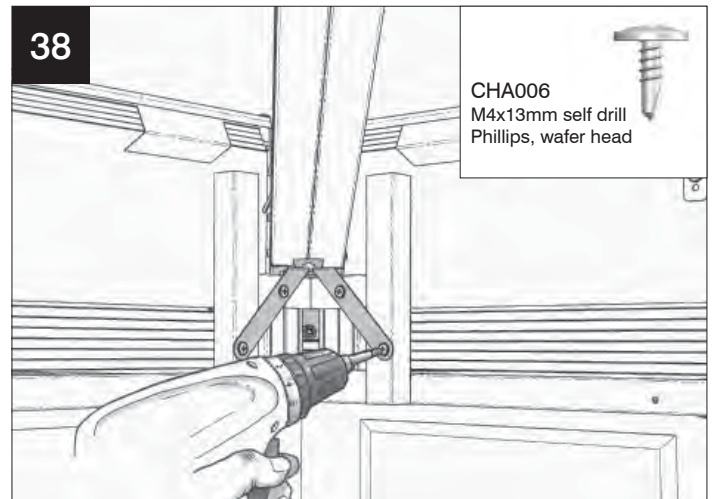

Next take the CHA010 hip bracket assembly and fasten the 'V' shaped element into the corner infill using 4 CHA006 M4 x 13mm self drill wafer head Phillips screws.

APPENDIX 2 - BOLSTER BARS - GLASS BOTH SIDES

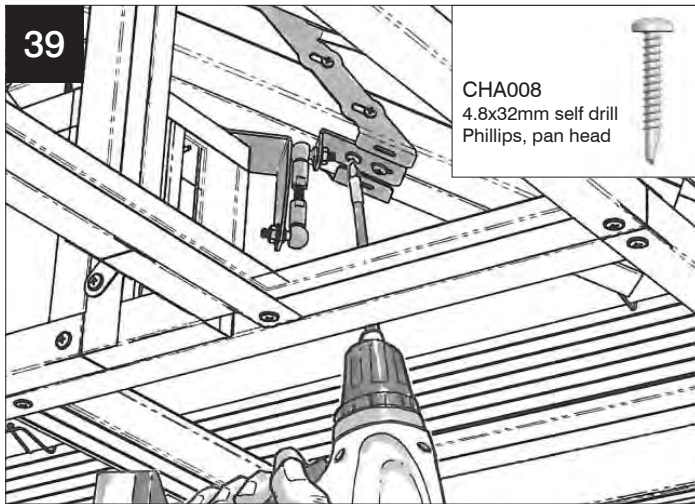

Now, screw up through the horizontal ladders to complete the assembly of the CHA010 hip bracket assembly using two CHA008 4.8 x 32mm self drill panhead Phillips screws. Ensure horizontal ladders are level.

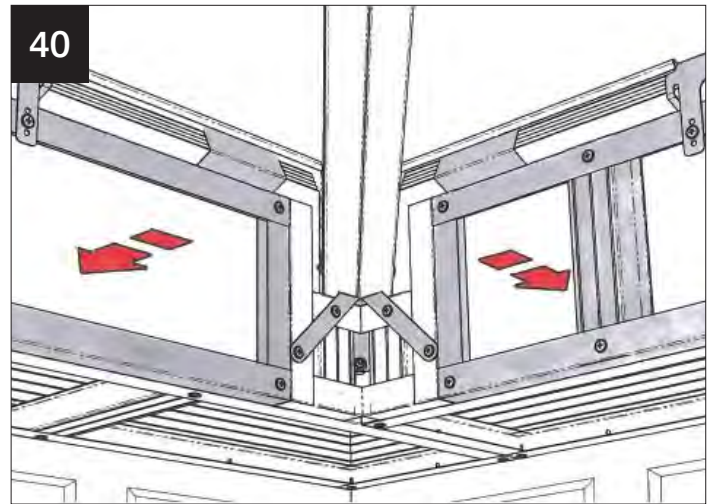

Using the location plan, choose the matching vertical ladder and offer it into position - hold firmly whilst attaching to the matching horizontal ladder using M4 x 13mm fixing, at 250mm centres into pre punched holes. Ensure the vertical ladder is behind the brackets.

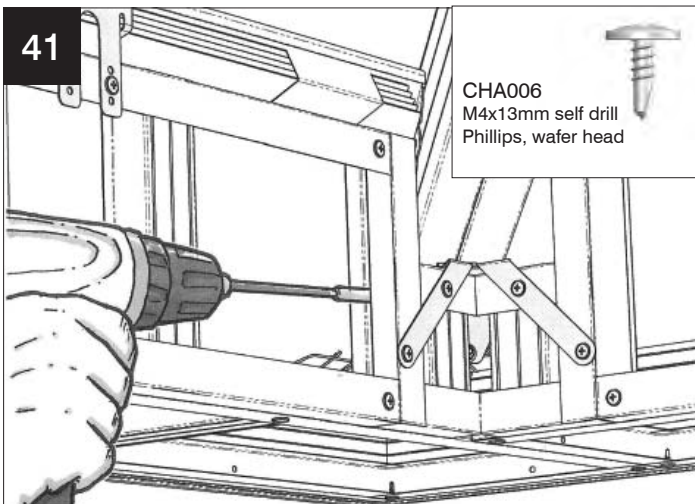

Butt the vertical ladder into the side of the corner infill - secure using two CHA006 M4 x 13mm self drill wafer head Phillips screws. Use two per vertical ladder.

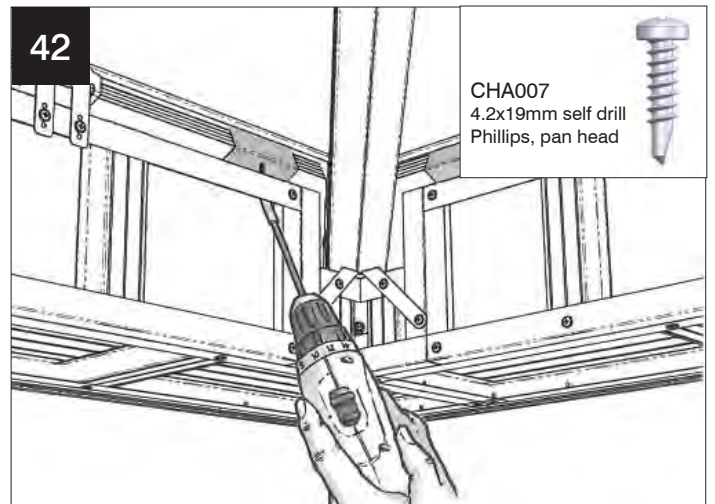

Now secure the top edge of the vertical ladder into the 100mm fixing channel - use two CHA007 4.2 x 19mm self drill panhead Phillips screws

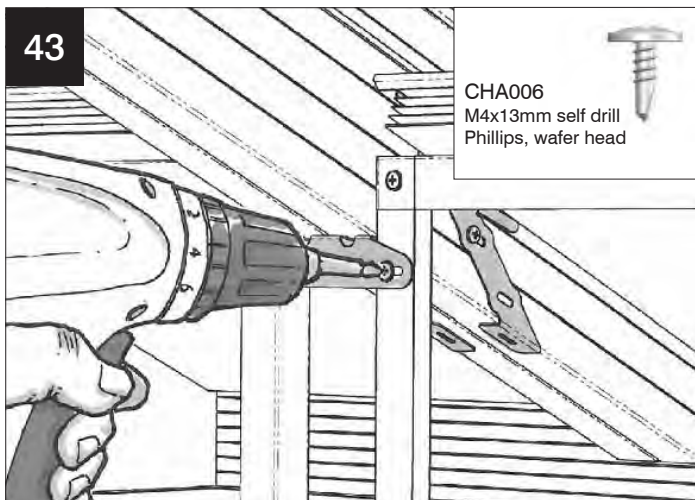

Secure the CHA009 bolster transom bracket at each side to the vertical ladder using CHA006 M4 x 13mm self drill panhead Phillips screw.

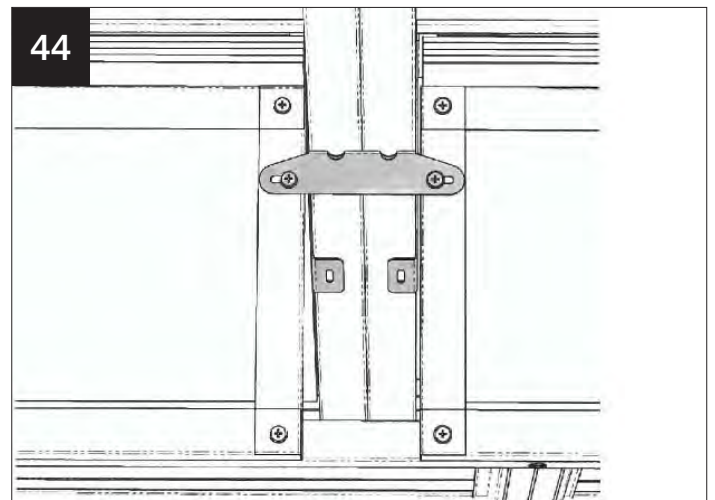

This is what the final transom bar should look like.

APPENDIX 3 - BOX GUTTER INSTALLATION

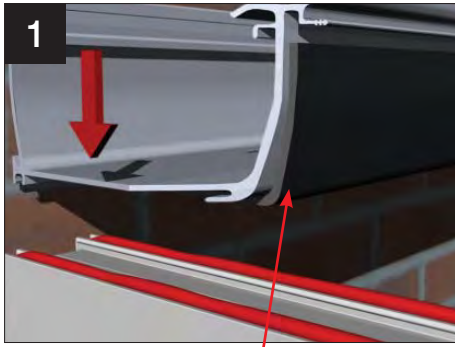

Box gutter foam to be cut back 70mm* to enable the box gutter to sit flush on the frames.

Apply a continuous bead of appropriate sealant to the front and inner legs of the window frames. Lift insulated box gutter into position – ensure it has adequate support whilst fitting.

* May be less than 70mm - measure frame and reduce cut back if necessary.



Place eaves beam section – with under gutter trim attached – onto the side frames. Seal the joint between the eaves beam and box gutter

NOTE: IF FITTING CORNICE, REMOVE THE UNDER GUTTER TRIM.



Whilst ensuring that its level, drill through the back edge of the aluminium at 600mm centres. Bolt to the house wall using masonry anchors that are suitable for the substrate (not supplied).



Either peel back or knife off a small amount of the insulation where the cleat is to be fixed. Drill a 4.5mm pilot hole and then fix the cleats with the two M5 12mm taptite screws provided.. The protruding taptite screws will need trimming back prior to fixing the adaptor (alternatively, when its time to insert the adaptor, undue the taptites, drill a pilot hole through the adaptor and then re-screw the taptites and fully seal).

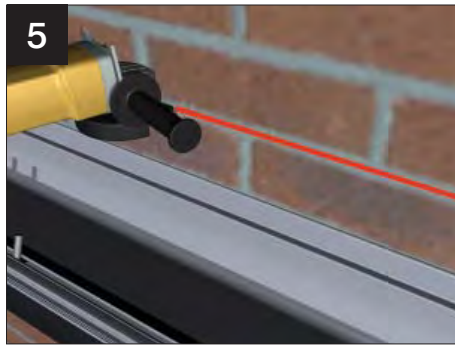

Mark out and grind a channel in the masonry for the flashing – blow out any dust in the channel.

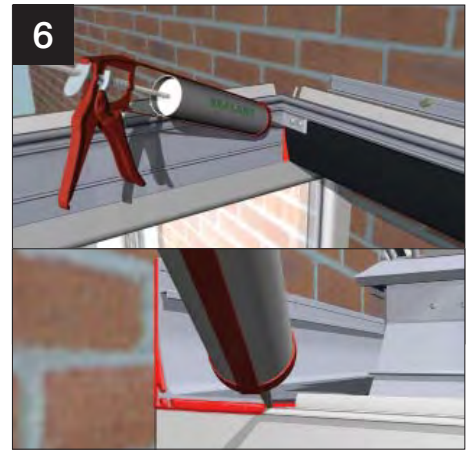

Now seal the internal joint between the eaves beam and box gutter and back point the leading edge of the box gutter where it sits on the side frames. Knife off a small section of the undergutter trim in preparation for the insertion of the adaptor.



Now, from the bag in which the adaptor is supplied, take the special tube of sealant, Gutterbond. Apply a generous bead of it evenly across the mouth of the box gutter, 20mm back from the front edge.



Slide the adaptor into the aluminium box gutter, raising up its front edge to utilise the unique `snow plough` effect. This spreads the Gutterbond evenly under the adaptor. Push the adaptor firmly up to its end stop, so that it will line through with the Classic gutter attached to the eaves beam.



With the adaptor tight to the end stop, turn the toggles upwards to firmly press the adaptor into the Gutterbond.

APPENDIX 3 - BOX GUTTER INSTALLATION

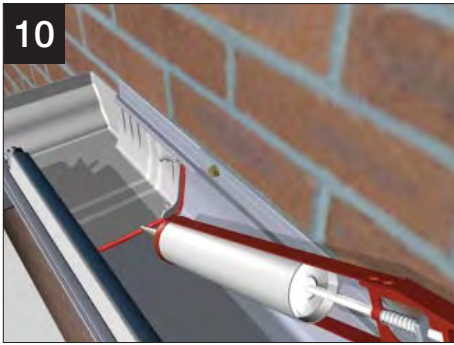

Use the balance of the Gutterbond to back point any gaps at the front edge.

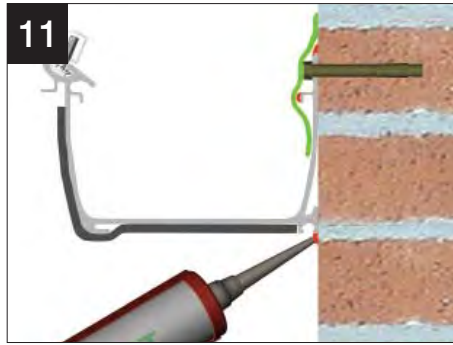

Seal the top and bottom edges of the aluminium box gutter, where it abuts the house wall.



Lastly locate the upper legs of the fascia board on to the box gutter. Finally seal the undercladding against the house wall.

APPENDIX 3 - BOX GUTTER JOINTING

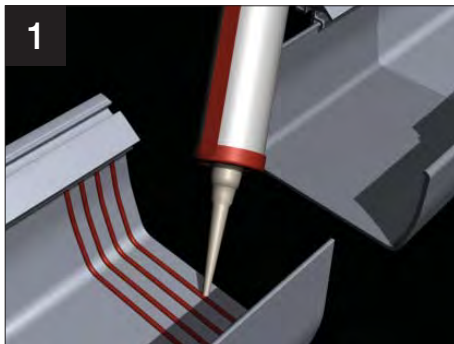

Thoroughly clean the mating parts using wire wool. Surfaces must be clean and grease free. Apply a generous bead of low modulus neutral cure to the pre-fixed internal sleeve along the entire face of the sleeve.



Drill through the top edge of the aluminium box gutter at 600mm centres. A fixing must be positioned within 50mm each side of the joint. Offer second half of the box gutter up to the internal sleeve and push firmly on. Fasten this second box gutter run to the host wall with masonry anchors suitable to the substrate. Ensure both sections are level and flush.

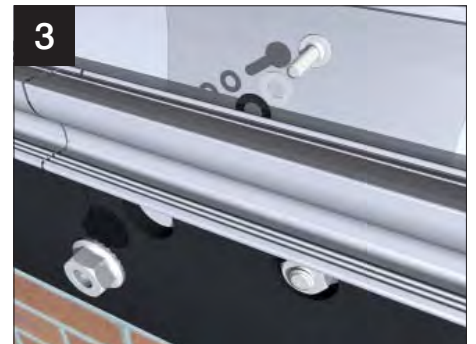

Drill 6.5mm holes through the box gutter and sleeve (at positions shown, ensuring both halves of the box gutter are flush together) and fix using the bolts, nuts and washers provided and in the order shown. Trim any excess off the bolt head before fitting the internal cladding as it may foul.

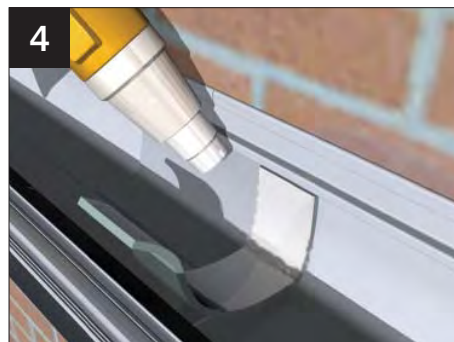

Check surfaces are dry, clean and grease free. De-grease if necessary. Heat both the sealing tape and the box gutter with a heat gun and position the tape over the joint. Press the tape firmly across the joint of the sleeve and the box gutter ensuring there are no air pockets.

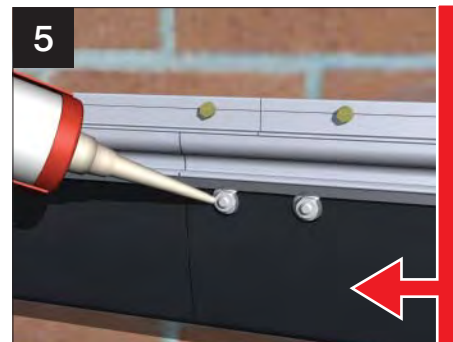

Now seal over all the exposed bolt heads, on the inside and outside of the box gutter.

ALL box gutters (especially those with tie bars or joints) MUST be supported.

Ultraframe recommends several types of support for box gutters including brick piers. Fitting a conservatory box gutter without adequate support will lead to structural failure. Please take the correct steps BEFORE installation.

APPENDIX 3 - BOX GUTTER SUPPORT

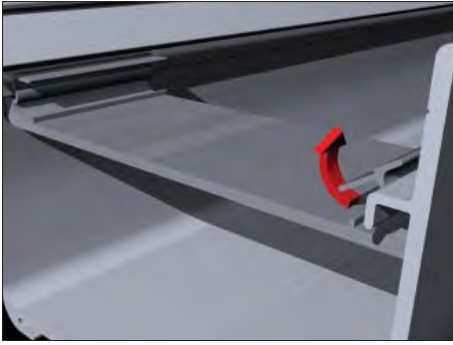

BOX GUTTER STRAP

165mm box gutters

These are supplied loose and **MUST BE FITTED** – they are a structural requirement of the roof. The straps must be installed within 75mm of glazing bar centres (when measured from centre of the strap to the centre of the bar). To install these straps, simply ‘nip up’ as shown.

265mm/special box gutters

Straps are factory welded into position.



BOX GUTTER HANGER

165mm box gutters

If these have been specified by your company at the time of order they are supplied loose and must be fitted.

The structural requirement for the hanging brackets are 2 x hanging brackets (sat side by side) at a maximum span of 2300mm unless the roof has a tie bar or joint on the boxgutter which should then be positioned in the same area.

Drill through the head of the hanger into the centre of the masonry, avoiding the mortar joint if possible. Use a masonry anchor suitable for the substrate. Lead flashing should be dressed down over the hanger, and snipped around the sloped leg. To attach it to the box gutter, simply ‘nip up’ as shown.

265mm box gutters

Hanger not available.



GALLOWS BRACKET

These are available for 165/265mm box gutters.

To install, notch out the insulation to ensure metal to metal contact between the extruded box gutter and gallows bracket. Offer up the gallows bracket and mark it ready to drill – always try to line up with the centre of a brick rather than a mortar joint. **Drill the gallows bracket and fix using three masonry anchors that are appropriate to the substrate.** Finally, notch out the undercladding, offer it into position and clip in.

Maximum centres are 2300mm. If the roof has a tie bar installed or a joint within the box gutter, then a gallows a gallows bracket should be installed directly underneath it.

APPENDIX 3 - RAISED BACK BOXGUTTERS

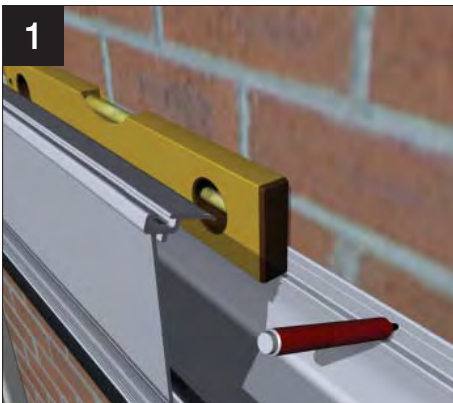

Offer the raised back or special box gutter into position. Carefully mark onto the aluminium leg against the host wall the position of each fixing – **use 600mm maximum centres using masonry anchors that are appropriate to the substrate (not supplied).**

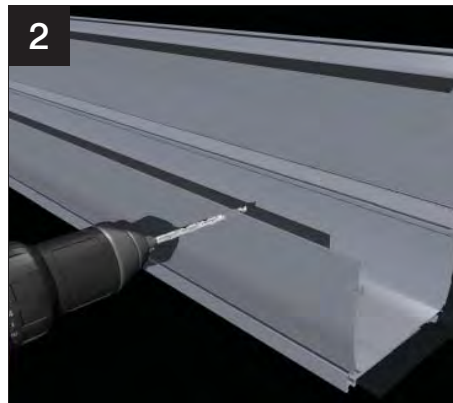

Lift the box gutter down to the ground and turn it around. Drill through the aluminium leg (that abuts the host wall) at the pre-marked positions. Whilst the box gutter is on the ground, seal along the front/rear face where the deep skirt sits inside the head of the extruded box gutter.



Lift the box gutter back into position, check levels, and then mark the wall (through the pre-drilled holes) ready to drill the host wall and grind out for the flashing.

APPENDIX 3 - RAISED BACK BOX GUTTERS

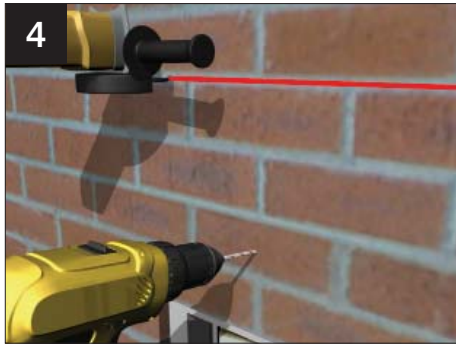

Remove the box gutter and drill the host wall where marked. Grind out the course which is at least one course higher than the raised back height.

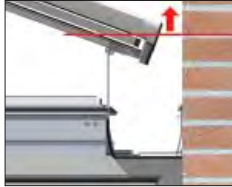

Offer the box gutter into position and insert the anchor fixings that are appropriate for the substrate and tighten up (not supplied).

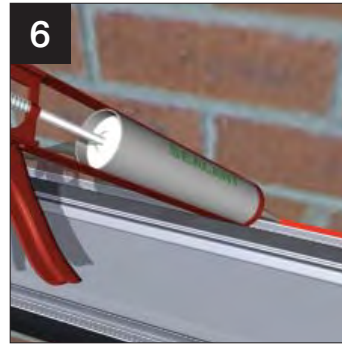

Seal the top and bottom edges of the box gutter and follow all other steps as per standard box gutters on page 54-55. When installing the lead flashing, ensure that the top of the flashing is higher than the point of the rain water discharge from the glazing bars. Clad off the deep skirt of the raised back box gutter using multi-board (not supplied).



Place the inline strap (SES005, 165mm / SES006, 265mm) over the single gutter roofing bolt on the sloped gutter. Temporarily fix the bracket to the host wall using three M8 sleeve anchor bolts (SAB001) supplied. Fit the starter bar. Secure the strap to the eaves with the two fixings supplied (UZBGF001-D). Finally, fix anchor bolts.

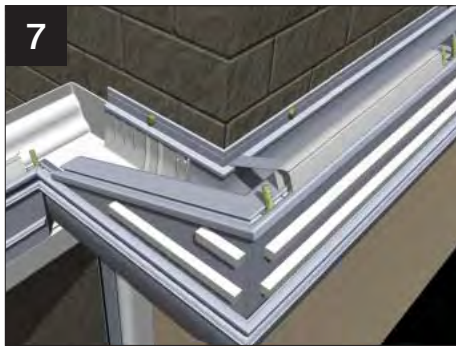

Following steps for the installation of box gutters on pages x-y, check that the roofing bolts are in position (i.e top and bottom of the slope)

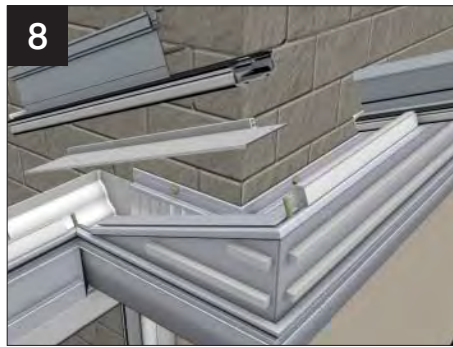

Place the short lengths of firing top cap and modified starter bar on to the two bolts. Please note that the bolts should be staggered, one each side of the bar.



Lift the 'L' shaped sealed unit into position and carefully position. Your office may have not ordered an 'L' shaped unit but may have split the unit into two, use a muntin bar to joint them (see page 34 of the Classic Install Guide for details of muntin bars).



Knock down the glazing bar top cap so it is finished flush with the bottom of the bar.



Two end caps are provided, one left hand and one right hand. Cut the end cap across its width so that it fits snugly to the face of the glass, remove it and then using the correct sealant, refit.

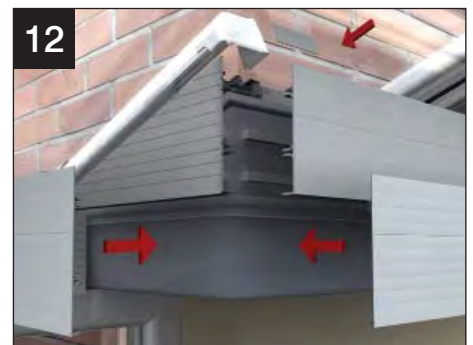

Internally, cloak off the open end of the glazing bar by fabricating a small end closure – seal into place. Fit the lower fascia and box gutter claddings in the usual way. Scribe and secure the upper claddings to the factory applied horizontal sticky tape strips. (For raised back box gutters beyond 300mm in height, vertical claddings must be fabricated from your own supplied multi board).

APPENDIX 3 - RAISED BACK BOX GUTTER - LIVINROOM

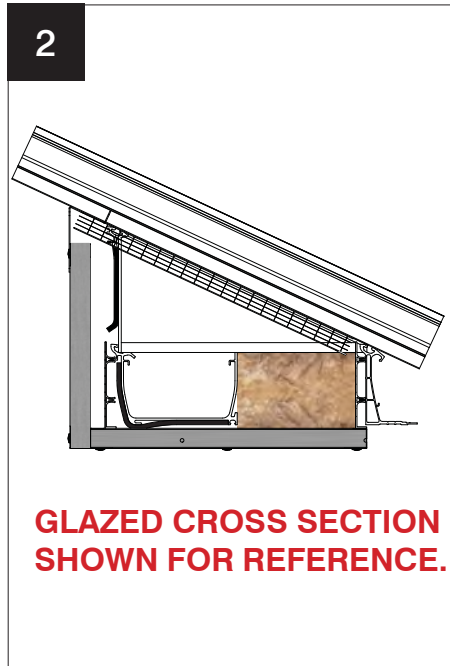

If the area around the box gutter is glazed fit brackets in marked positions on the bars as per standard installation and fit closure trims CHA---GR/5 according to layout plan.

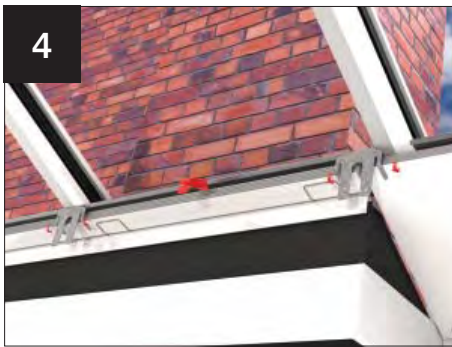

Fit the polycarbonate modesty panels and bend over bracket legs to secure.

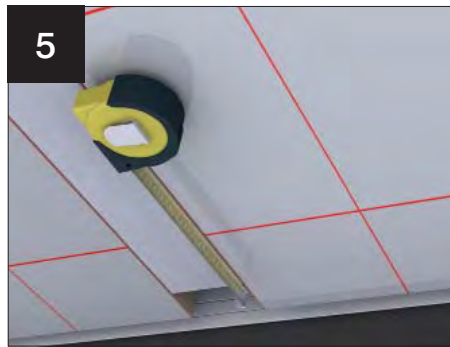

If the area around the box gutter is solid, use location plan provided to measure up and mark from the bottom of the steel bolster.

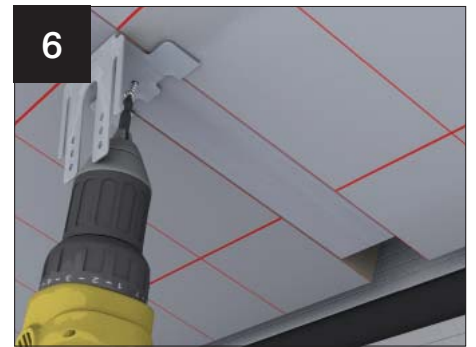

Take the transom bracket supplied and attach using the fixings provided.



If the area around the box gutter is solid, additional insulation will be specified. Fit 90mm insulation block to front face of the internal box gutter fascia with silicone- this will help to prevent cold bridging.

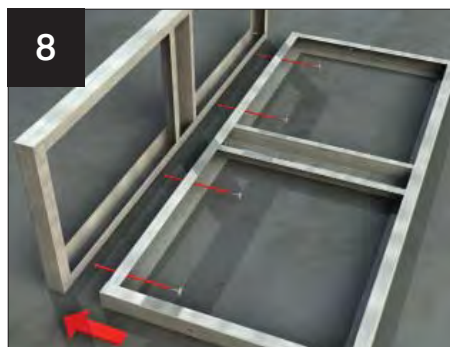

Assemble matching vertical and horizontal frames- use fixings at 250mm centres into pre-punched holes. Ladders will have different heights depending on whether adjacent panels are glazed or solid.



Offer up into position and fit in place using CHA006 (bag of 25).

APPENDIX 3 - RAISED BACK BOX GUTTERS

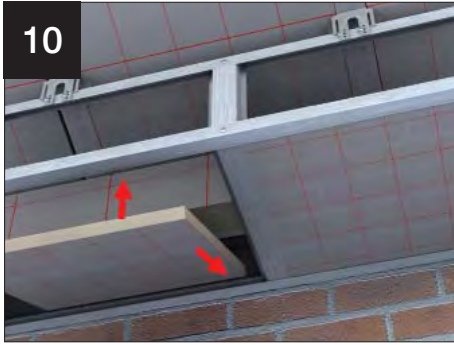

In solid areas, fit 25mm insulation beneath the gutter- offer up the back edge into the rear insulated internal pelmet channel first, then pivot up and slide into position, engaging with the front insulated internal pelmet channel to secure.



In the case of an L-shaped conservatory, where the box gutter returns around the house wall. If the distance between the side gutter fascia and the adjacent transom bar is less than 100mm, 90mm insulation will not be specified and a gap will remain- in this case, insert mineral wool to fill the cavity.



Fit 25mm insulation adjacent/beneath gutter around the return as shown in step (10) to help prevent cold bridging.

APPENDIX 4 - VALLEY INSTALLATION - EXTERNAL

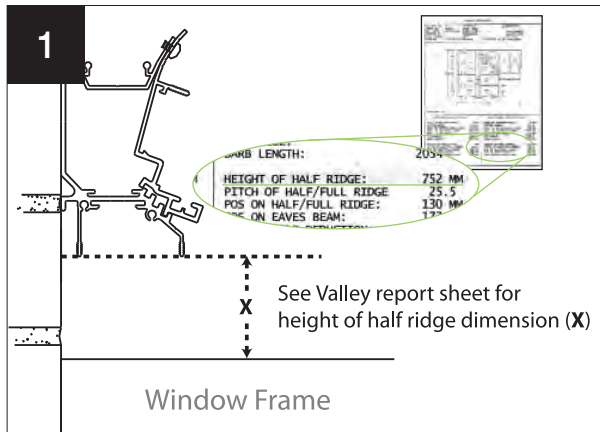

For exact half ridge location, please check as above.



Assemble as much of the main Georgian (or vic) roof side of the 'P' shape as possible. CHECK THE PITCH. Ensure the full ridge is level. Separate the two part half ridge. REMOVE THE RAIN BAFFLE UPPER LEG. Fit the back section of the half ridge in position, level across the PVCu top carriages (as shown), then secure to the host wall with anchor bolts suitable for the substrate. The first anchor to be 50mm away from full ridge, the second 250mm and then at max 600mm centres.



Re-assemble the two parts of the half ridge, ensuring that the front carriage is located in the one of six possible positions. To do this make sure that the original screw holes for the self tapping screws line up. Ensure the profile is fully engaged along its length. Use screws provided at pre-set centres to attach the two parts of the half ridge.



Next, pick up the aluminium valley section, ensuring the under cladding location barbs are slid into position. Then, offer the valley up to the roof and locate onto the captivated bolts in the ridge, half ridge and eaves beam. Tighten the four nuts holding the valley in place.



Re-fit the half ridge rain baffle. NOTE: If glazing with 24mm glass units or 25mm polycarbonate, the rain baffle upper leg needs to be set in the highest position.

APPENDIX 4 - VALLEY INSTALLATION

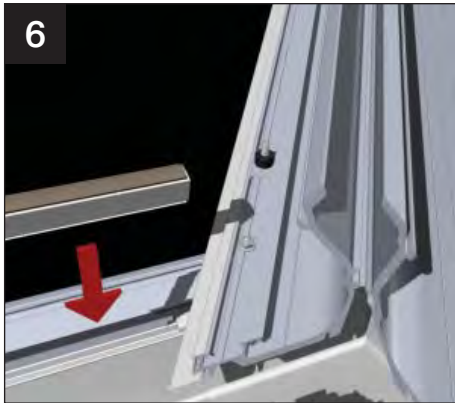

Re-fit the glazing support trim, where the valley meets the eaves beam.



Now run a continuous bead of suitable silicone down the entire length of the aluminium valley profile, at the point of the hinged connector in the centre.

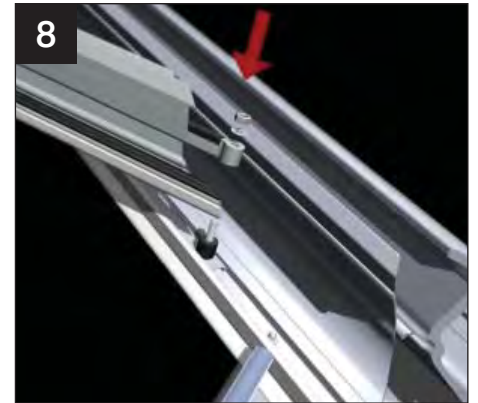

Using the location plan provided, assemble the various glazing bars onto the valley. Use the washers and nuts provided to ensure a robust joint is created.

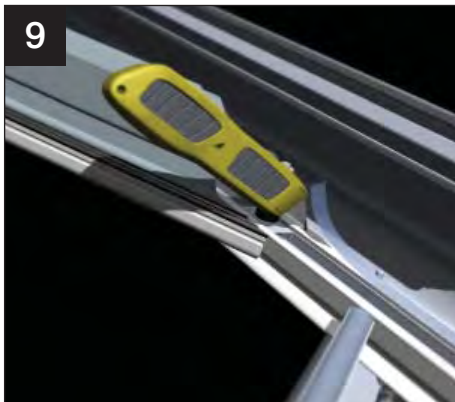

Fit the double sided sealing tape to each of the valley wings. Tease one end of the protective tape loose, crease it about 50mm in from the end and fold over ready to extract once the glazing panels are laid in position.

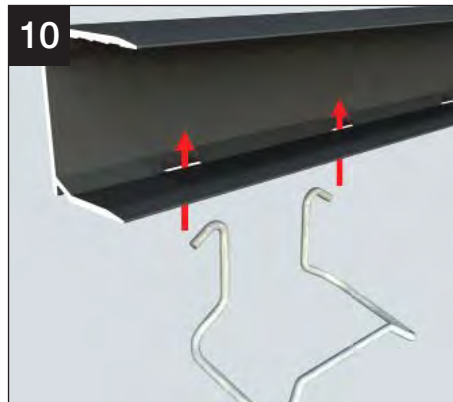

Each glazed or solid roof panel on a valley should be fitted with 2 x wire clips to hold it in position. Insert the clips through the pre-cut slots within 100mm of each end of the glazing end profile as shown.

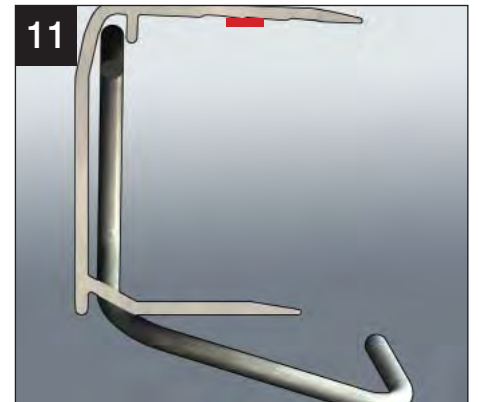

The hooked 'ears' should locate behind the protruding aluminium lip detail as shown. Fit to the panel and apply a continuous bead of relevant sealant (MS polymer on self cleaning glass). Slide into position on unit and wipe clean any sealant from surface. **(Sealant position indicated in RED).**

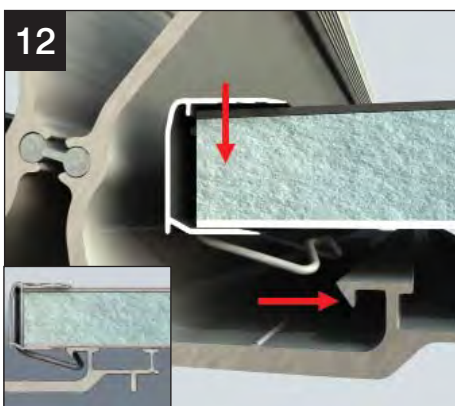

Place the panel in its correct position (refer to location plan if in doubt). Position the end profile down into the valley as shown. With the glazing pressed flat against the valley profile and your fingers underneath, pull the panel up into the rain baffle and allow the clip to 'spring' into position and 'lock' the glazing in place. Once properly fitted, the clip should lock into place as shown (inset).



Fit the valley end cap using the two plastic rivets supplied.



The joint between the full and half ridge PVCu top caps is sealed by the use of a capping connector. This needs to be trimmed to suit. Bed the capping on suitable silicone and fix using the plastic rivets provided.

APPENDIX 4 - VALLEY INSTALLATION - INTERNAL - SOLID

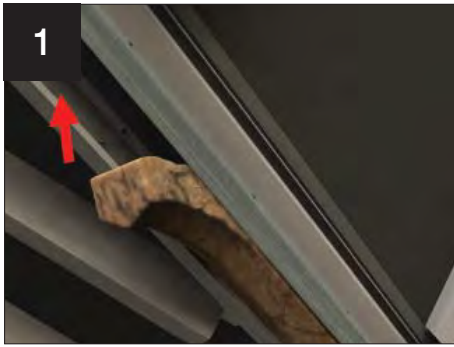

1
Insert mineral wool (LVIR001) between the valley wings along the whole length to insulate the cavity.

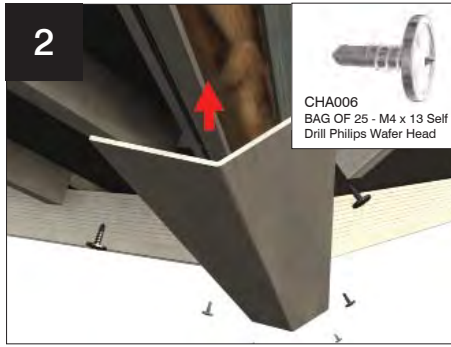
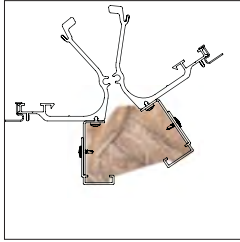

2
Fix valley plate (LVPV300) to underside of plastic spacers at 250mm centres.

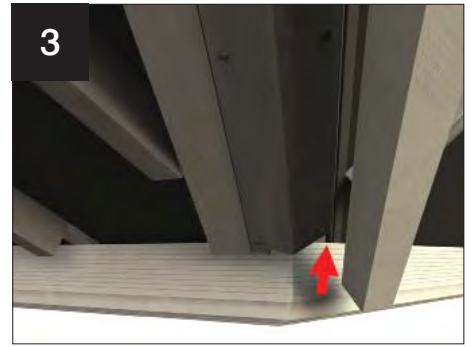
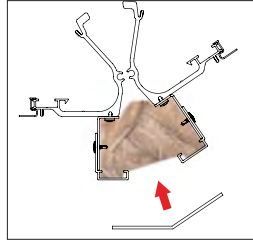

3
Position and fit polystyrene valley insulation where shown using silicone to secure.

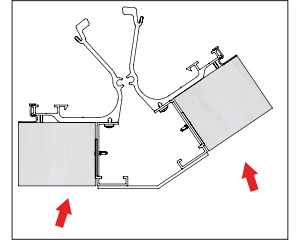

4
It may be useful to fit an angled batten at the host wall – this will provide a positive fixing point when fitting the plasterboard.

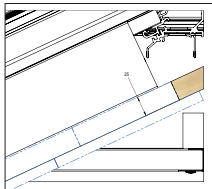

5
Insert mineral wool along the length of the wallplate.

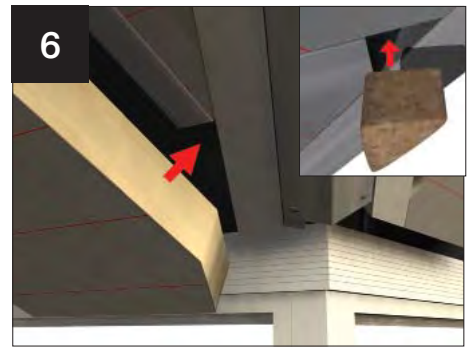

6
Fit 90mm insulation and fill voids in jack rafter positions with mineral wool to minimise potential for cold bridging.

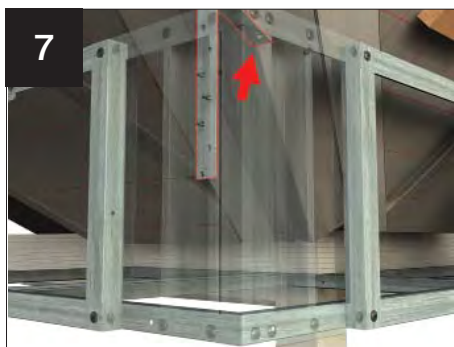

7
Now fit the LivinRoom. The valley bracket should be anchored to the valley plate as shown.



8
Fit a length of timber batten to the host wall, ensuring that its underside lines through with the underside of the struts (LVTS001/LVTS002). This will provide a fixing point for the ridge board fitted in the next step.



9
Fit the ridge board as described on page 39.

APPENDIX 4 - VALLEY INSTALLATION - INTERNAL - SOLID

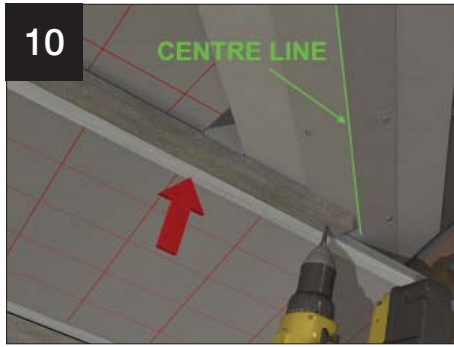

Fit the ridge battens, as described on page 39.
NOTE: On the valley side, the batten should terminate on the valley Plate centreline as shown.



When fitted, the 25mm insulation should butt up to the batten, and the plasterboard should fix through into the underside of the batten as shown.



Now fit the plasterboard – the detail where the valley abuts the host wall should look as shown.

APPENDIX 4 - VALLEY INSTALLATION - INTERNAL - GLAZED



Cut a 200mm length of valley undercladding. This will act as a template for the bottom scribe. Use a 'straight edge' placed tight to the eaves fascia, then mark and cut.

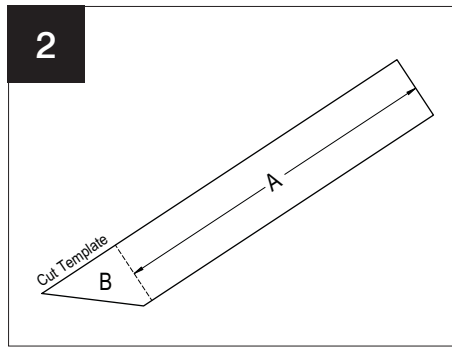

Measure dimension A then add B for overall length. Mark and cut the claddings for both left and right side. Push fit the claddings into position.

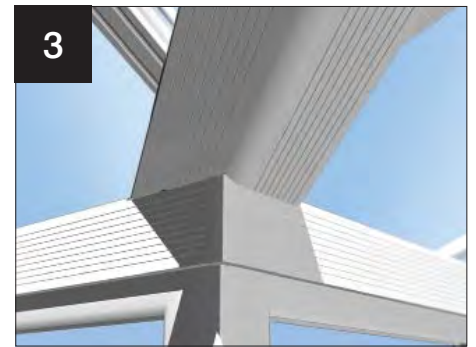

Valley claddings shown in situ at the eaves.

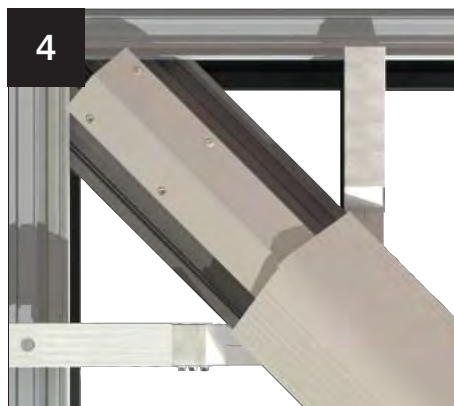

Valley claddings shown in situ where the valley meets the ridge.

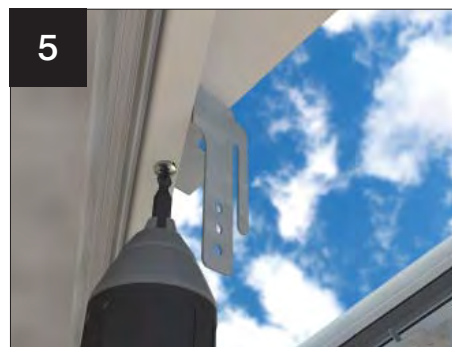

NOTE: The transom bracket CHA001 **MUST** be trimmed and adapted to suit situations where a transom bar, valley and insulated internal pelmet vertical frame intercept, as shown above.

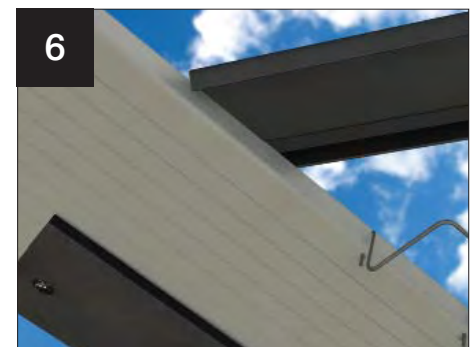

In valley situations the closure trim sits onto the valley drip profile. The nose of the closure trim must be notched as shown above, this allows the trim to sit flat.

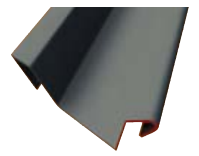

APPENDIX 4 - VALLEY INSTALLATION - GLAZED



Mark out and cut the valley cladding and fix valley fixing plate by following steps 1 - 5.



Using a level, plumb up off the horizontal frame and mark the outer bottom edge of the valley cladding on both sides (Mark "A").

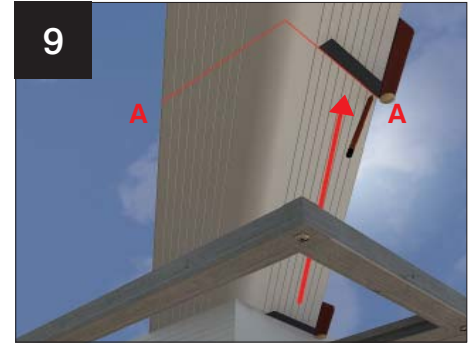

Using an angle finder (or joiners bevel). Draw a line on the valley cladding from the mark 'A' parallel to the eaves.

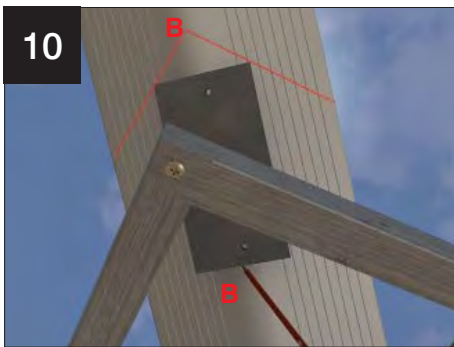

Temporarily position the valley fixing plate central of the valley with the top edges touching the marked lines. Mark either side of the plate (shown as 'B' on the cladding). Now remove valley fixing bracket.

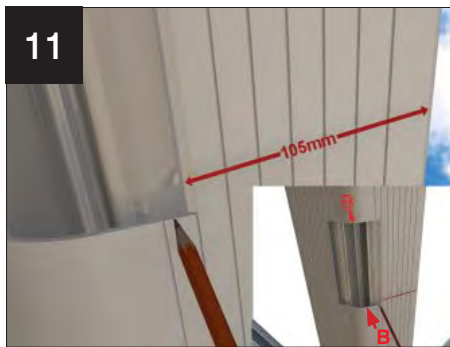

Then measure 105mm in from each side of the valley cladding and extend mark B top and bottom to form pencil rectangle. Cut out valley cladding.

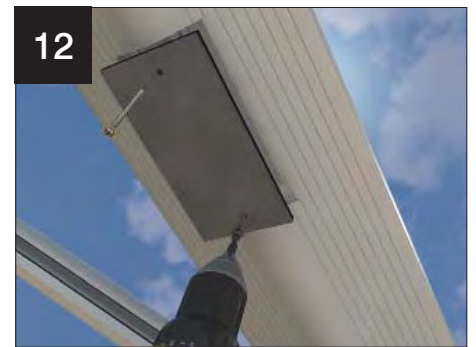

Fit valley plate, with foam backing towards the valley, to the valley wing central connector using CHA017 (2 X 4.8 X 70mm self tapping screws).

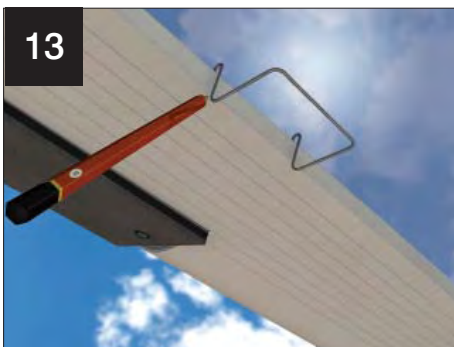

Fit the cloaking panel support clips CHA002 onto the valley cladding (2 per valley side supplied). Space out clips and temporarily hook over the valley cladding. Mark the leg positions then remove the clips. Drill a 5mm hole at each leg position as shown.

NOTE: AVOID DRILLING THROUGH THE VALLEY DRIP PROFILE



Refit the clips with the clip leg extending through the holes.



Attach the cloaking panels and fit as shown earlier.

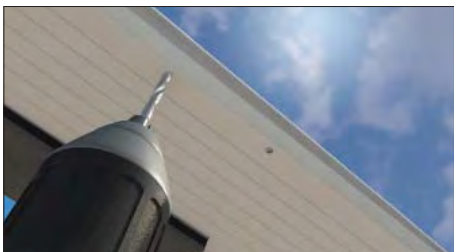

APPENDIX 4 - VALLEY INSTALLATION - GLAZED



Fit the valley corner infill panel to the horizontal frame, level up and secure to the valley plate.



FIT THE STRAP CHA018 USING M4x13 SELF DRILL SCREWS, to the valley corner infill panel and the valley fixing bracket. It may be necessary to bend CHA008 to suit.



Fit the vertical frames. Fix the frames into the valley corner infill and the horizontal frames.

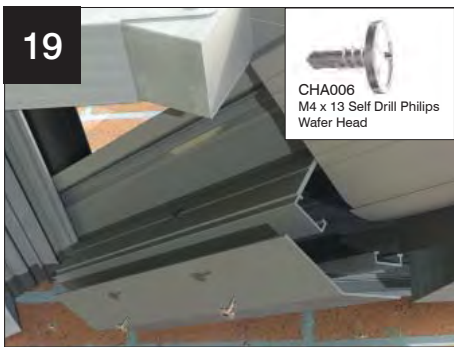

Fit valley plate at top of valley using fixings at max 250mm centres.

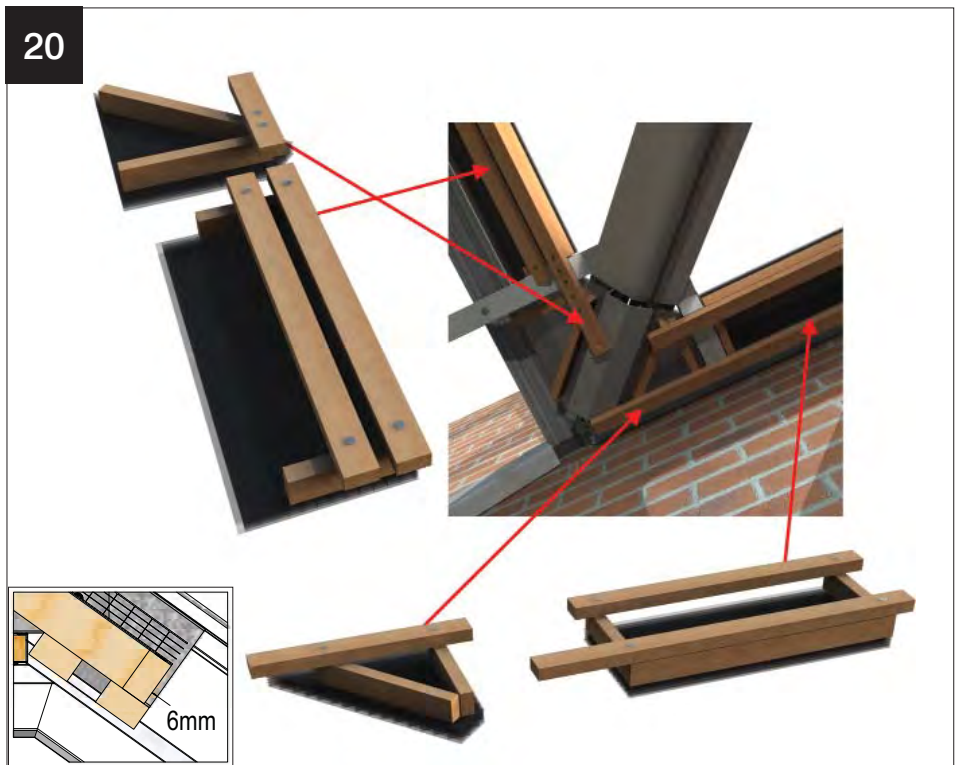

Fit modesty panels adjacent to valley – create cassette assembly as shown using double sided tape to fix battens to the polycarbonate and screw fix the support batten into position as shown. Offer up the modesty panel into position to define the position of the support battens.

Each of the 4 modesty panels immediately next to the valley, to its left and right, has a different make-up to ensure adequate fixing. Particular attention needs to be paid to ensuring that battens terminate at the centrelines of the steel undercladding so that adjacent panels can 'share' these anchor points. Battens approaching the valley itself can be screwed to the valley plate fixed to its underside. Ensure that the polycarbonate and attached battens are set back 6mm from the support battens to allow space for fitting the multiboard trim



Offer up the cassette assembly into position.

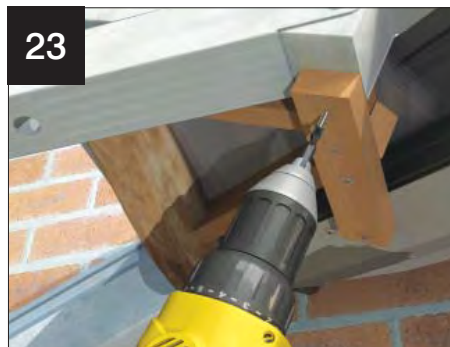

Fix into position using plasterboard screws. NOTE: when fitted, the battens should terminate at the centreline of the steel undercladding to allow for fitting of the adjacent panels

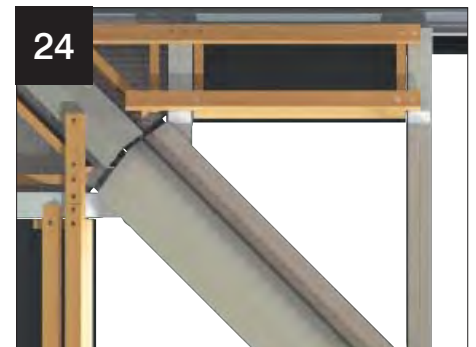

Fit adjacent panels by the same method as previous step. Again, terminating the battens at the centreline of the steel undercladding to allow the fixing of adjacent battens in the following steps. (Detail at wall plate shown)

APPENDIX 4 - VALLEY INSTALLATION - GLAZED

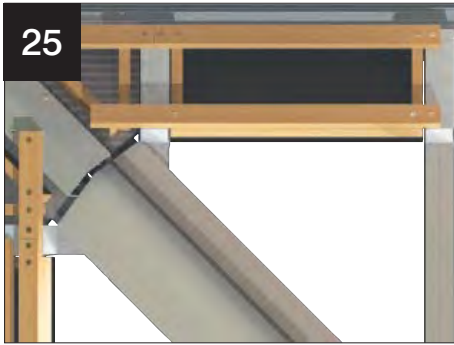

Detail at ridge shown.



Fit a length of timber batten to the host wall, ensuring that its underside lines through with the underside of the struts (LVTS001/LVTS002). This will provide a fixing point for the ridge board fitted in the next step.



Fit the ridge board as described on page 39.



Fit second row of battens as described on page 40.

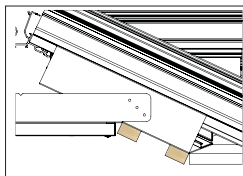

Fit additional battens where glazing is present along the host wall as shown.

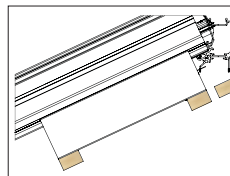

Slide remaining modesty panels into position, ensure that the batten on the screen is set 6mm back and screw fix to secure.

Fit black multi board trims into 6mm recess (refer to P41 for more information)

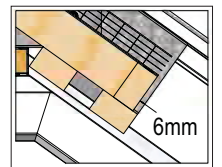

Fit 25mm insulation.

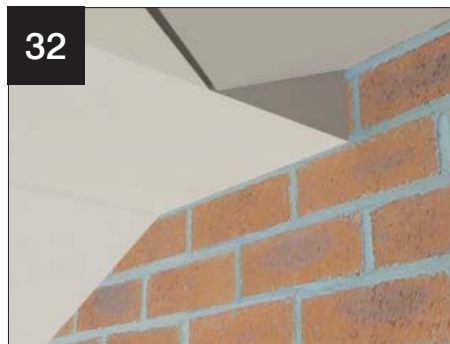

Now fit the plasterboard – the detail where the valley abuts the host wall should look as shown.
Fitters tip: fit the small triangular segment of plasterboard shown first, allowing space for the upper adjacent board to slide in above it, as there will be nothing to screw to at this point.

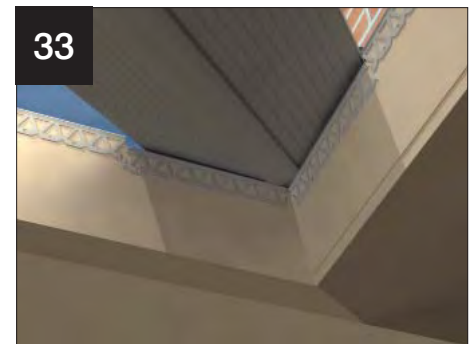

Where plasterboard intersects with the valley undercladding it should be notched to fit and fitted with LVPT250/1 PVCu plasterboard trim.

APPENDIX 5 - VENTILATED WALL PLATE

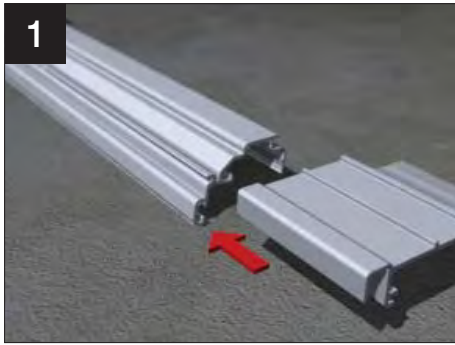

The aluminium wall plate body has been cut to length to extend 45mm beyond the side frames of the conservatory. Slide the aluminium carriages supplied with the wall plate onto the main body and space out at approx. 500mm centres.

NOTE: ROOFS WITH A PITCH OF 15° AND OVER SEE STEP 9

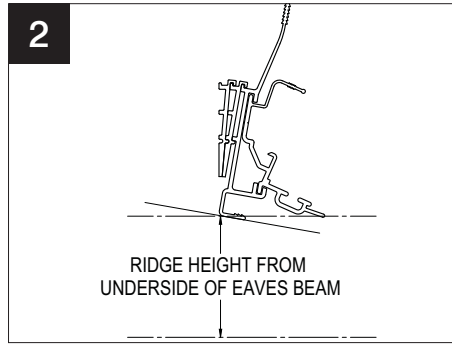

Offer the wallplate up to the wall – the height to the underside of the wallplate from the underside of the eaves (see above) can be found in the insulated internal pelmet setout plan paperwork.

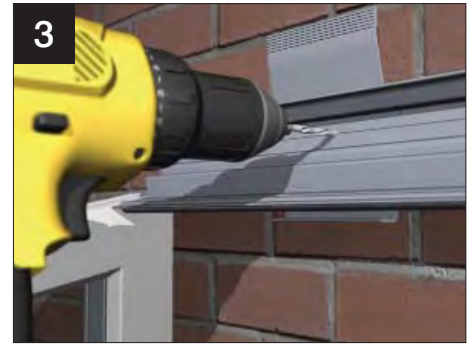

Drill through the wallplate main body and directly through each carriage to suit the masonry anchors being used (not supplied). Mark the position of each masonry anchor on the house wall and drill the house wall to suit.

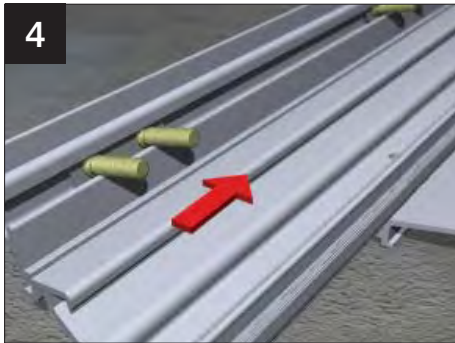

Make sure the appropriate number of roofing bolts are located in the bolt slot of the wall plate before finally fixing the wall plate to the wall.



Systematically install the masonry anchors at 500mm centres (Not supplied).

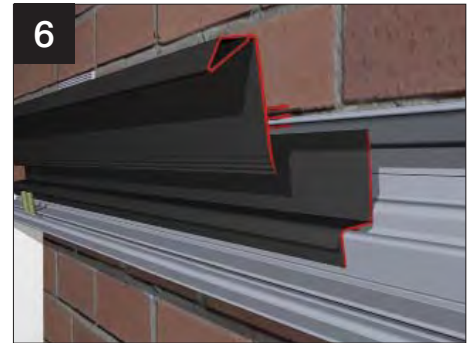

Fit the back and main baffle. (It is pre-cut to the external frame dimension - DO NOT CUT).



Attach undercladding, having first sub assembled the ventilation button (separate installation leaflet provided in vent button kit)

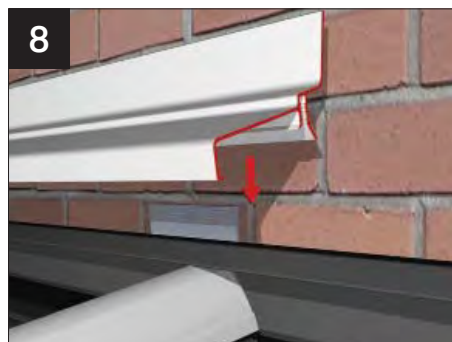

Cut the PVCu wall plate top capping to the overall width of the conservatory (externally) and notch over the top of the lean-to cloaking trim at each end. Push fit the wall plate top capping.

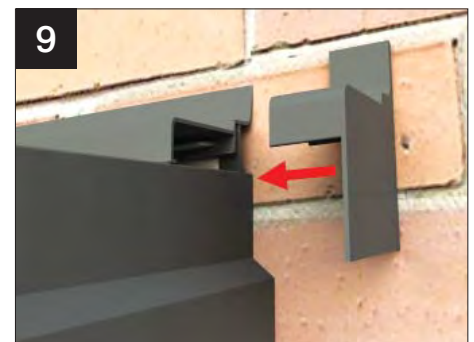

Trim the wall plate end caps and fit using sealant appropriate to the glazing. Fit lead flashing.

APPENDIX 5 - VENTILATED WALL PLATE

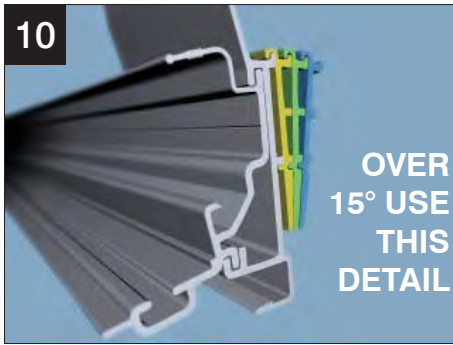

If the pitch of the roof is greater than 15° then the wall plate is supplied with a number of aluminium packers. These packers hook onto the back of each carriage and act as a wedge between the carriage and the house wall. These should be fitted when drilling and fixing the wall plate. The packers may be used in multiples and each packer will tilt the wall plate by 5°. When packers are used it will be necessary to ease the wall plate top capping back to the wall and secure with plugs and screws before dressing the lead flashing over the top capping.

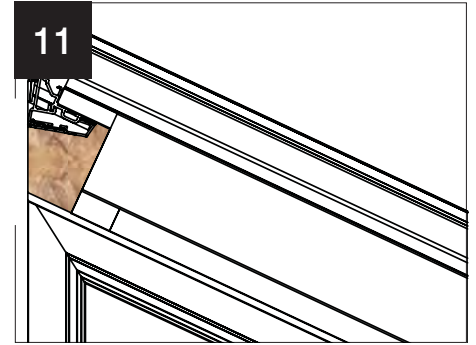

When insulating, ensure that the cavity underneath the ridge is filled with mineral wool insulation (supplied).

APPENDIX 5 - HALF RIDGE INSTALLATION

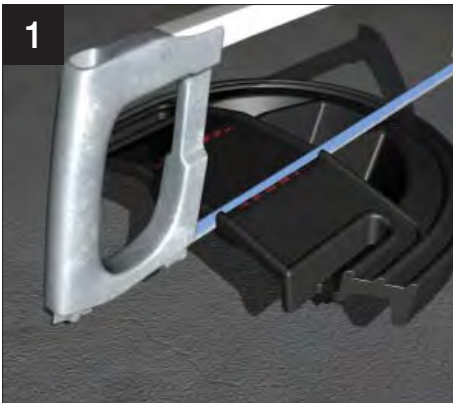

The weathering shield must be cut through the marked line. Note the illustrations shows the cut required for a left hand hipped end.

SEE p19 for further guidance on trimming the weathering shield to suit glazing thickness/bar positions.



Prior to attaching the starter bar to the mounted starter bar bracket, remove the M6 tapitite screw. Locate the bar on to the bracket and on to the single bolt placed in the eaves beam, re-insert the screw.



Check the half ridge for being level and then check the starter bar pitch. Drill and fix the die cast back plate to the host wall (avoiding mortar joints) using an anchor bolt suitable for the substrate. Drill and fix the starter bars(s).



Chase out and install the lead flashing. Add the pre-cut weathering shields. Seal the weathering shield to the host wall.



Glaze the roof. Fit and seal the top of the glazing bar top cappings. Install the ready assembled half ridge top capping and external radius end. Finally install the lead flashing to suit.

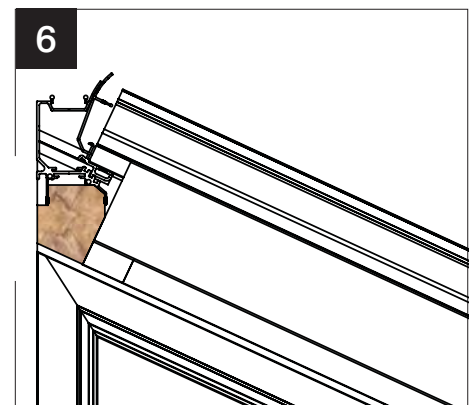

When insulating, ensure that the cavity underneath the ridge is filled with mineral wool insulation (supplied).

APPENDIX 6 - GABLE INSTALLATION

BEAM

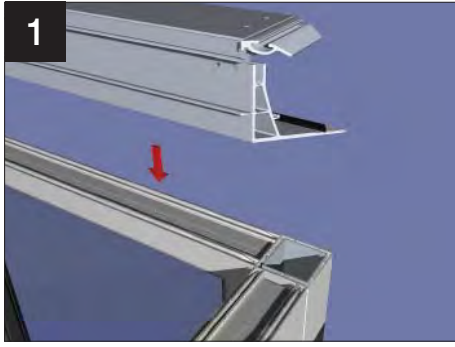

1 Trial fit the gable beam and the eaves beam ensuring the inside face is flush with the inside face of the window/door frames. Remove, then apply a continuous bead of silicone to both the front and rear edges of the window/door frames.

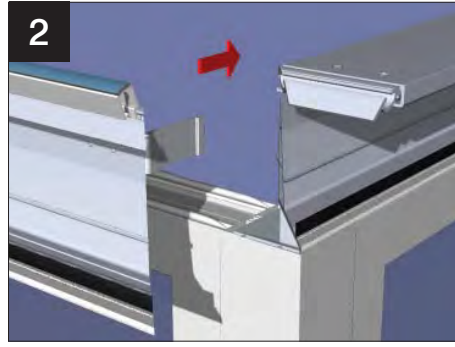

2 Fit the under gutter trim to each section of eaves beam and gable beam, position the beams and slide the corner cleats (already attached to the eaves beam) into the gable beam. Drill through the holes already in the gable beam into the gable beam. Drill through the holes already in the gable beam into the cleats and secure with the screws supplied.

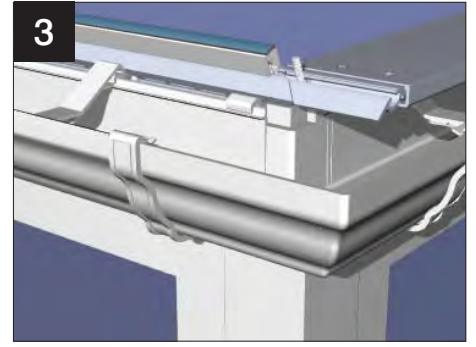

3 To secure the gable beam (see Vic Fixing Kit page 10 of Classic Installation Guide), then at this stage the guttering is installed. First attach the gutter brackets to the gable/eaves beam. Fit the 90 degree external gutter corners to the gable beam length of gutter. The brackets are at maximum 750mm centres and 200mm from each corner.

NOTE: IF FITTING CORNICE, REMOVE THE UNDER GUTTER TRIM.

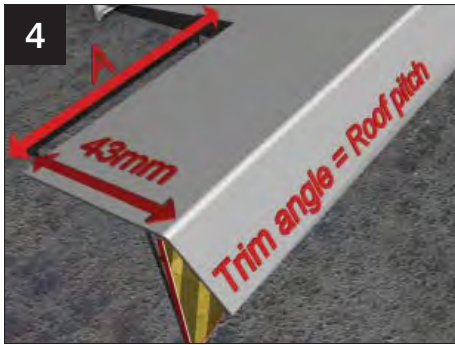

4 With the guttering in place, trim the gable beam top cladding. The cladding is supplied over length and cut to suit the roof pitch (see table).

Roof Pitch (°)	Dim A (mm)
10	83
15	85
20	87
25	89
30	93
35	98
40	104

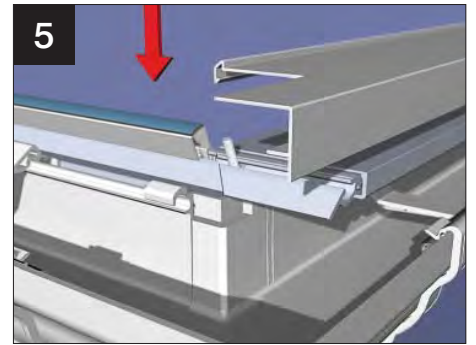

5 Next attach the notched gable beam top cladding on to the head of the gable beam.

APPENDIX 6 - GABLE INSTALLATION - DUO PITCH

FRAME

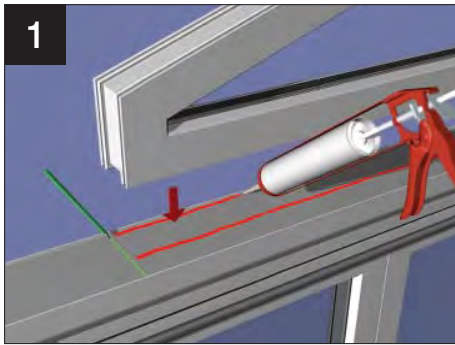
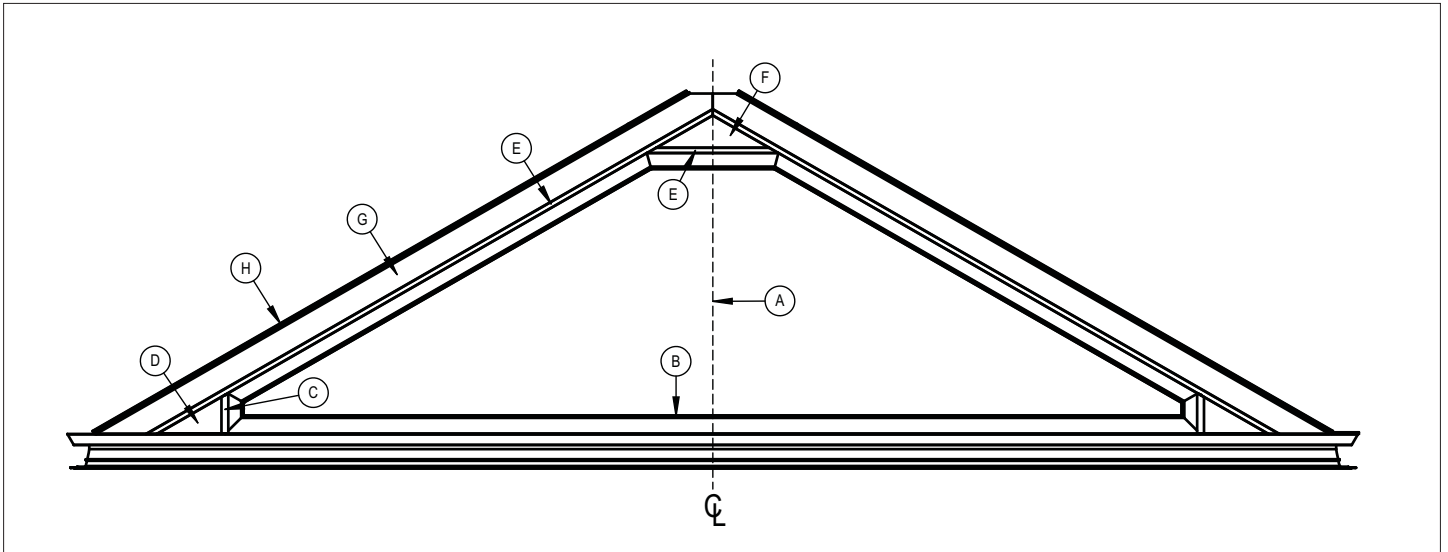

1 Position the gable window frame central to the gable beam (A), and mark the position. Remove the frame and again run two beads of silicone along the head of the gable beam top cladding (the width of the window frame only). Replace the frame centrally and back against the upstand of the gable beam top cladding. Fix securely through the frame into the head of the gable beam (B) with self tapping screws (not supplied).

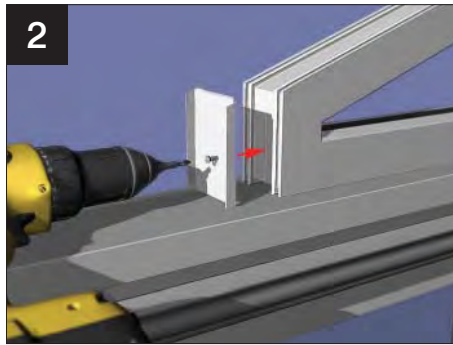

2 Mark and cut the gable infill end cap (C). Notch inner bottom edge to allow the end cap to sit flush and tight to the gable window frame. Trim top edge to suit pitch of roof and gable frame firing top cap which should be placed into position for marketing purposes. First silicone and then screw the end cap to the gable frame.

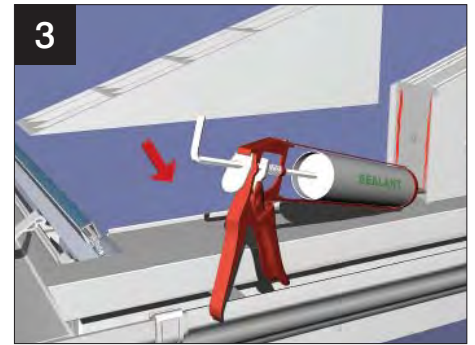

3 Trial fit the gable infill wedge (D). Remove, run two beads of silicone and place back in position, tight up against the infill wedge end cap. **NOTE: it will be necessary for non standard pitches to trim the infill wedge to suit the pitch, maintaining the 135mm height dimensions.**



4 Cut the 'H' sections, mitring where necessary for a neat flush appearance (E). Fit these and the apex wedge (F) using continuous beads of silicone. **NOTE: it will be necessary for non standard pitches to trim the apex wedge for a correct fit**



5 Fit the hollow core beams into position on top of the 'H' section (G). Screw up through the window frames as shown to secure.

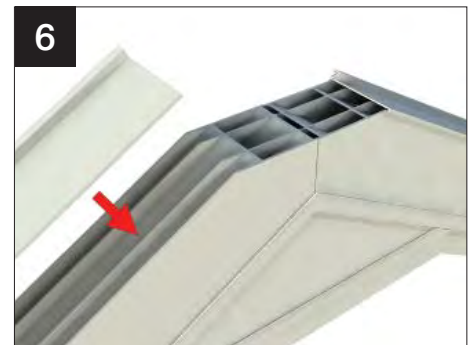
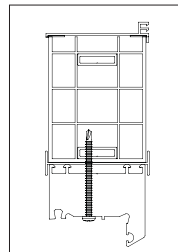

6 Position the beam top cap (H) along the firing. The bottom edge of the cap should be cut to finish flush with the gable beam. The top edge should be square cut to terminate at the horizontal beam cut, as shown.

APPENDIX 6 - GABLE INSTALLATION - DUO PITCH

RIDGE

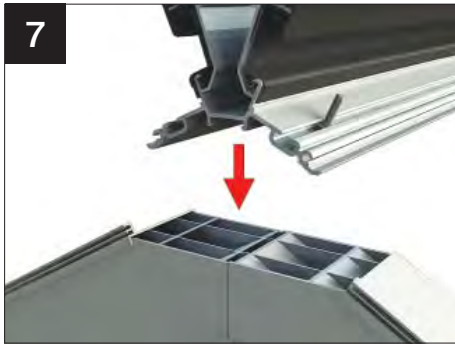

Place and support the ridge, ensuring it is central to the gable frame.



Place the starter bars onto the beam top caps and secure to the ridge and eaves beam. Securely fix the starter bars to the beam - screw through at an angle as illustrated to ensure a solid fixing into the aluminium reinforcement.

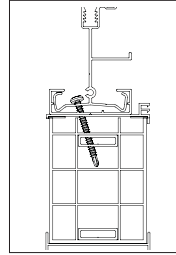

Once the panels are in place, fit the starter bar top caps into position.

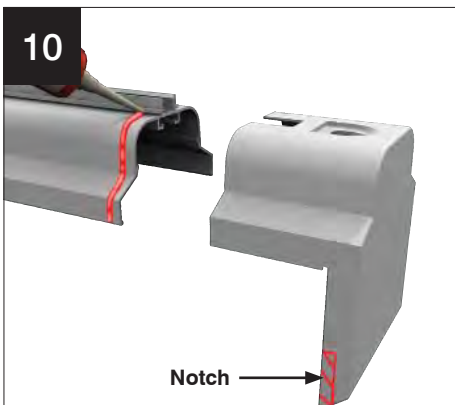

Take the Gable end cap - Create notch as shown to fit around the beam and seal the ridge body as shown.



Using plastic pop rivets supplied, drill as shown and install rivets - avoid 'flat top' of profile.



Scribe and cut the bottom end of the cloaking trim horizontally for a flush fit on the gable beam.

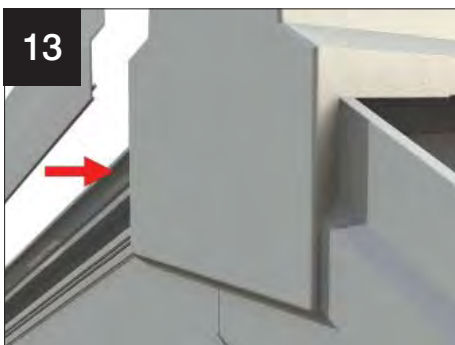

Offer the cloaking trim up to the side of the gable ridge cap and scribe to suit the roof pitch - push into place against the end cap.



Finally, fit the starter bar end cap.

APPENDIX 6 - GABLE INSTALLATION

- LEAN-TO (10.1° AND ABOVE)

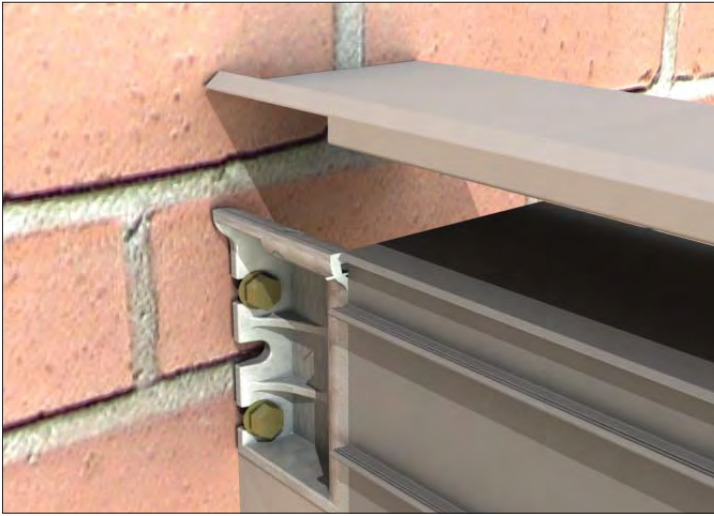

The gable beam will be pre-fitted with a structural moulding. This has three fixing points to allow attachment to masonry- choose holes that align with solid masonry and attach using resin anchors suitable for the substrate/loads. When fitting the gable beam cladding, it will be necessary to trim a small section at the host wall as shown to allow it to sit over the structural moulding (fixings not supplied).

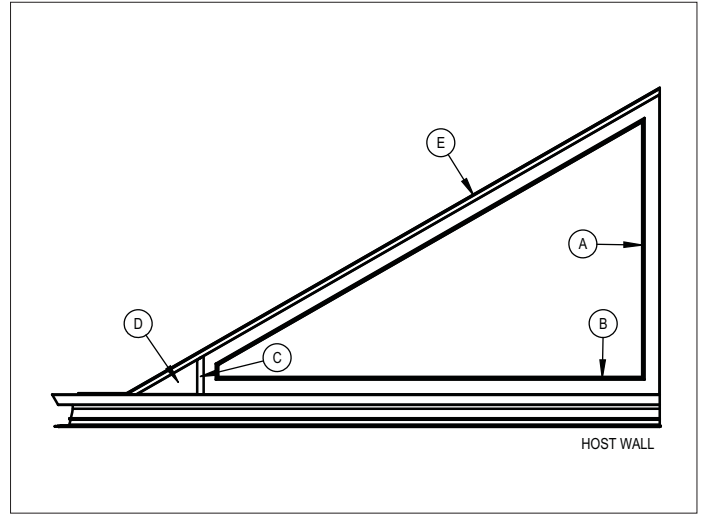

Note: In certain cases, where custom frames are specified, the lower wedge (D) will have to be fabricated on site.

NOTE: THE WALL PLATE MUST BE FITTED BEFORE FITTING THE GABLE FRAME



1 Align window frame with host wall (A) and follow steps(1-5) on page (70).

NOTE: Lean to roofs do not include an apex wedge



2 Fit hollow core beam- screw up through window frames as shown, then fit the furring top cap using appropriate sealant.



3 Securely fix the starter bars to the gable furring -screw through at an angle as illustrated to ensure a solid fixing into the aluminium reinforcement.



6 Fit starter bar claddings, cloaking panels and half ridge top cap (if applicable to your choice of ridge). Scribe half ridge end cap to fit into 'shoulder' of cloaking panel and fit using silicone.



7 When plasterboarding the internal it may be useful to fit an angled batten at the host wall - this will provide a positive fixing point when fitting the plasterboard.

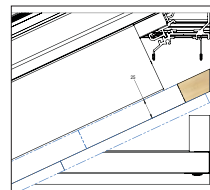

8 When fitted, the 25mm insulation should butt up to the batten, and the plasterboard should fix through into the underside of the batten and terminate at the host wall as shown.

APPENDIX 6 - GABLE INSTALLATION

- LEAN-TO (10.09° AND BELOW) - EXTERNAL

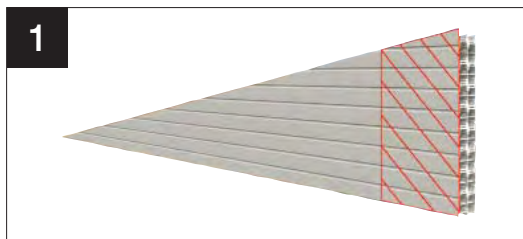

On lean-to's of 10.09° or below, a solid furring will be specified. This will be supplied over-length and will require cutting to size on site.

Roof Pitch	Half Ridge		Variable Ridge		Parabolic Ridge	
	Dim A (mm)	Dim B (mm)	Dim A (mm)	Dim B (mm)	Dim A (mm)	Dim B (mm)
5	97	11	67	10	59	23
6	97	11	67	10	59	24
7	97	11	67	10	59	25
8	97	11	67	10	59	25
9	97	11	67	10	59	26
10	93	11	68	10	59	27

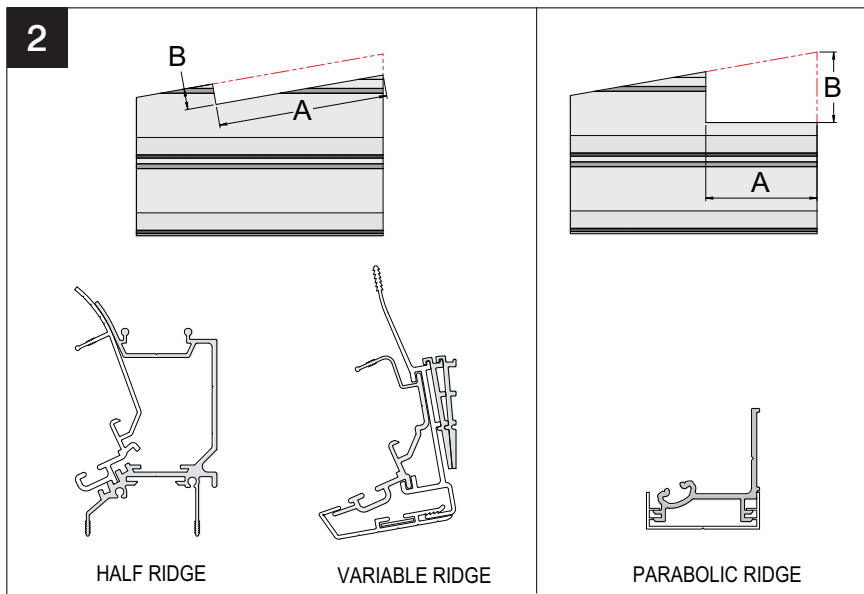

It will be necessary to create a notch detail in the furring at host wall to allow the ridge body to pass through- use the table shown as a guide for cutting. NOTE: A different cut profile is required depending on your choice of ridge.



With the wall plate pre-fitted, offer up the furring into position- pushing it up against the upstand on the gable beam cladding.



Screw up through the pre-drilled holes in the gable beam at 400mm intervals to secure the furring firmly in place. Use screw pack LVFFOIO (supplied) .



Notch the furring cover and top cap to fit round the ridge body as shown. Fit into place with continuous beads of silicone.

Fit starter bar and top caps as described on page 67. Screw through starter bar into furring to stabilise.

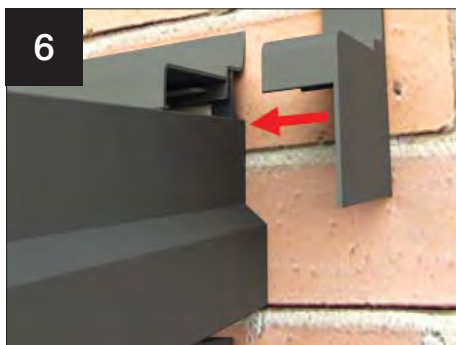

To complete the exterior scribe the end cap to fit over 'shoulder' of the cloaking panel.



Fitters tip: The notch created in the furring (see above) will leave a visible gap on the exterior under the cloaking panel- if the furring is grey, the offcut from the end cap (trimmed in the previous step) can be used to create a 'patch' to cover the gap.

APPENDIX 6 - GABLE INSTALLATION

- LEAN-TO (BELOW 10°) - SOLID - INTERNAL



8
If the roof panel adjacent to the furring is SOLID - After fitting 90mm insulation, screw fit CHA405/1 channel where the 90mm insulation converges with the inside face of the furring this serves to carry the edge of the 25mm insulation and offers a surface to screw the plasterboard to. The channel should span between the host wall and the LivinRoom frame.



9
Fit the 25mm insulation and plasterboard to the ceiling before continuing to the next step.

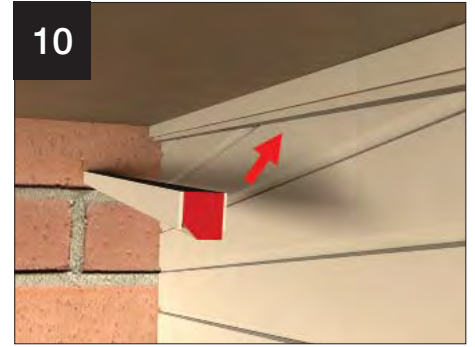

10
Fit MTB004 packer (with LVGS double sided tape each side) where the plasterboard converges with the inside face of the furring this will create a level surface to fit the timber frame created in the next step.

APPENDIX 6 - GABLE INSTALLATION

- LEAN-TO (BELOW 10°) - GLAZED - INTERNAL

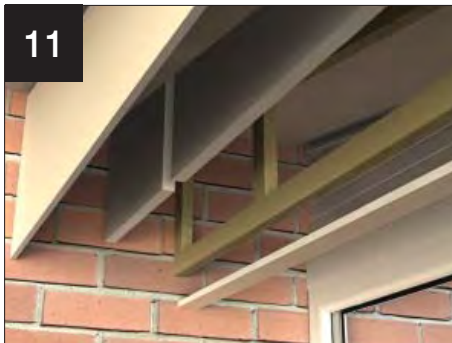

11
Fit the frame into position against the furring, fill the cavities with 25mm insulation and finish with plasterboard.



12
If the roof panel adjacent to the furring is glazed- In order to fit the cloaking panels (as described on page 41) you will need to screw fit a length of CHA405/1 channel to the furring to carry the timber battens and 25mm insulation - this will also provide a surface to screw up through when fitting the plasterboard.



13
Fit the 25mm insulation into place between the battens and into the steel channel.

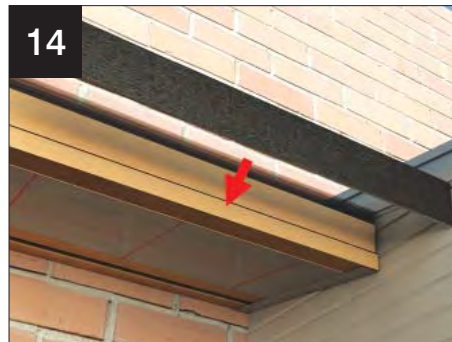

14
Fit black multiboard into position against modesty panel. Ensure it touches the glass and fix using drywall screws.



15
Fit a 13mm x 44mm batten along the furring between multiboard and insulated internal pelmet frame as shown. Push the batten up to the underside of the furring top cap (see inset). Also, fit upright timbers above eaves fascia at 600mm centres. Stack a 19mm x 44mm batten of equal length on top of the 13mm horizontal batten and screw through to secure.

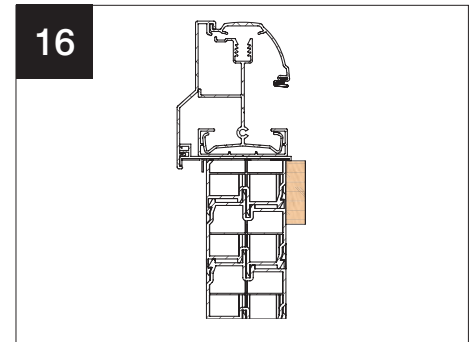

16

APPENDIX 6 - GABLE INSTALLATION

- LEAN-TO (BELOW 10°) - GLAZED - INTERNAL

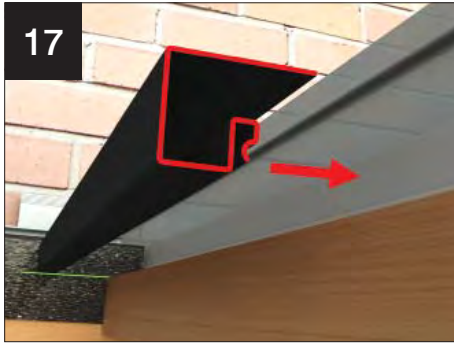

Slide LFS600 black plastic trim into place between the glass and timber battens as shown. This creates a solid black detail when viewed from the outside.

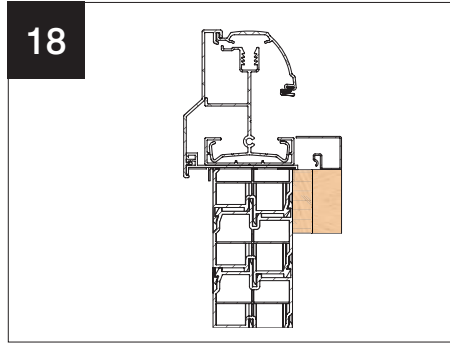

Section view of LFS600 trim and timber batten positioning.



Fit black multiboard, covering timbers and enclosing LFS600 black plastic trim- again, ensure it touches the glass and fix using drywall screws.

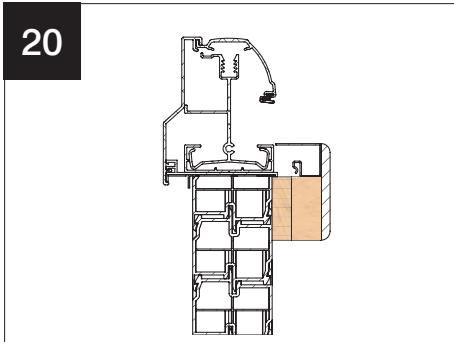

Section view of multiboard positioning.

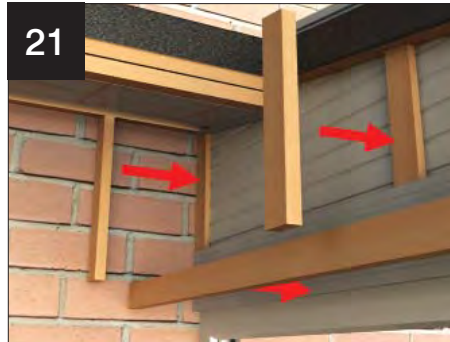

Add a framework of 25mm x 44mm battens this should consist of 1 horizontal batten along the lower edge of the eaves fascia and uprights stacked on top of the 13mm verticals installed in step 15.



Fill the cavities between the timbers with 25mm insulation and finish with plasterboard.

APPENDIX 6 - GABLE INSTALLATION

- LEAN-TO FULL HEIGHT WALL BOUNDARY CONDITION

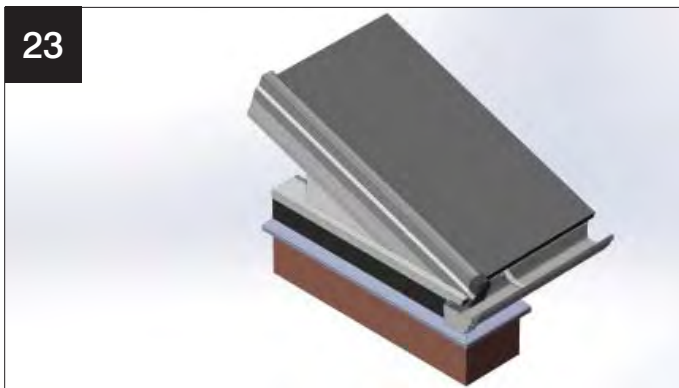

Gable support beam sits on full height wall / cill, no gutter returns.

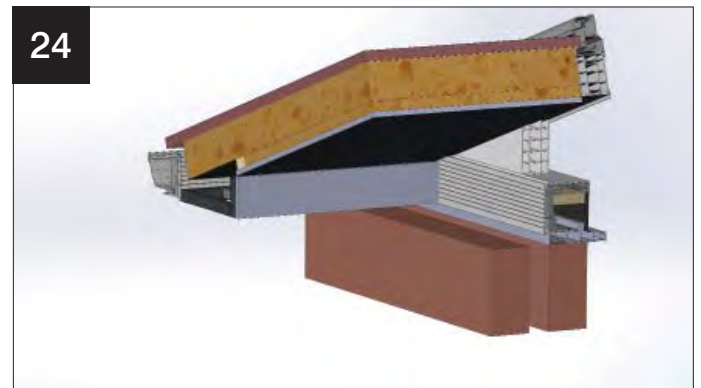

Gable support beam sits on full height wall / cill, no gutter returns.

APPENDIX 6 - GABLE INSTALLATION - INSULATED INTERNAL PELMET - SOLID

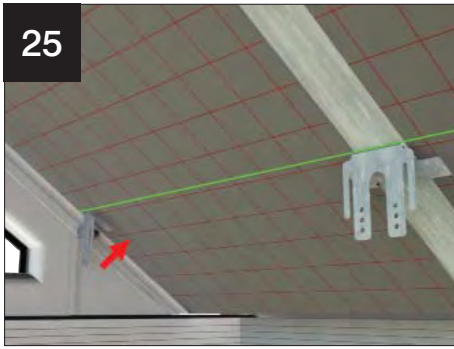

25 In solid situations- line gable bracket CHAAD19 through with bracket on adjacent bar and push up into 90mm insulation. Screw through gable using CHADDS self drill screws.



26 Fix the vertical frame into the fascia board using 2 x CHA006 (M4 x 13mm) self drill Phillips, wafer head screws (supplied).



27 Now fit living room channel to gable- this is used to carry 25mm insulation and to secure timber battens and plasterboard adjacent to the gable.

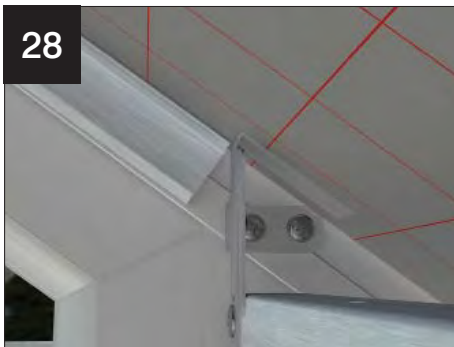

28 where panel adjacent to the gable is solid - the channel spans from insulated internal pelmet frame up to ridge detail and should be fitted directly below the 90mm insulation (insulated internal pelmet detail shown).

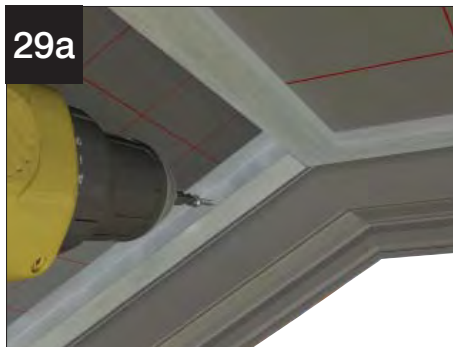

29a Duo-pitch ridge detail shown - channel terminates at ridge board.

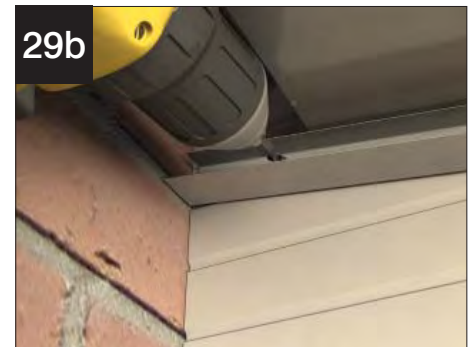

29b Mono pitch detail shown - channel terminates at host wall.

APPENDIX 6 - GABLE INSTALLATION - INSULATED INTERNAL PELMET - SOLID

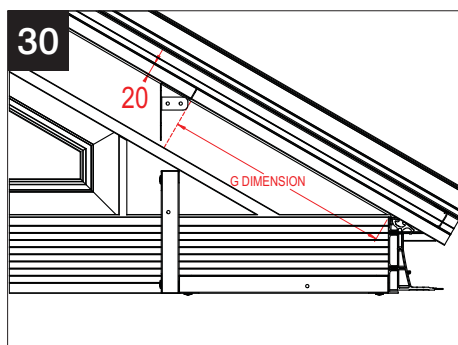

In glazed situations - see location plan for G dimension and set bracket shoulder 20mm below glazing. Screw through gable using CHADDS self drill screws.

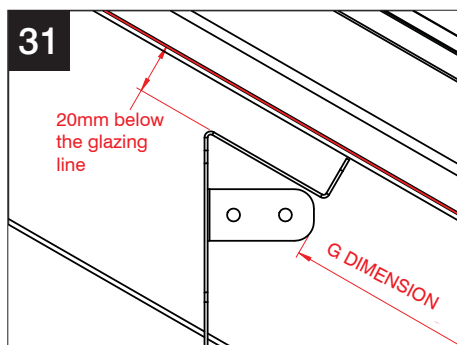

Close up detail - N.B. the bracket MUST be set 20mm below the glazing line as shown.



The 'nose' of the cloaking panel support trim must be notched back around the bracket as shown (at gable side only).

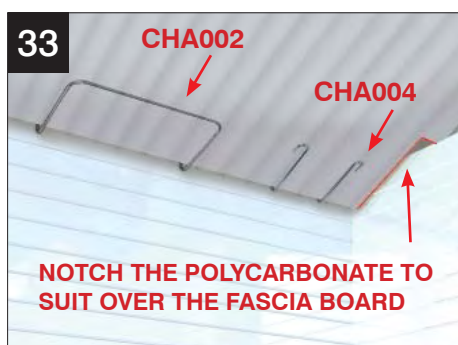

Referring to the location plan, take the appropriate piece of polycarbonate cloaking panel, mark and notch the corner as demonstrated.

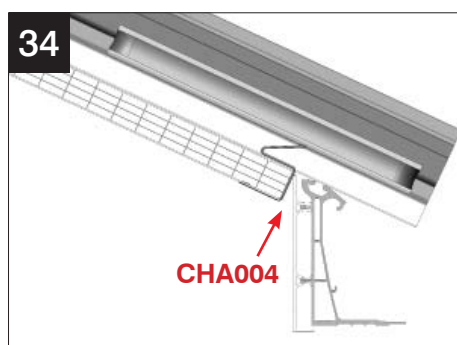

Attach CHA004 to the cloaking panel and fit as shown.

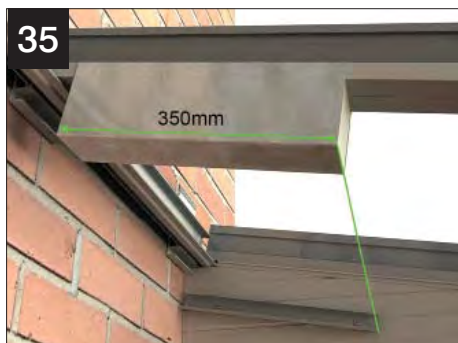
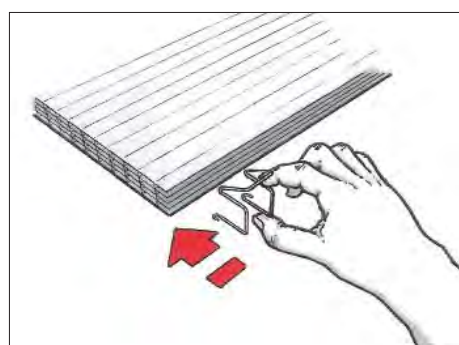

Where panel adjacent to the gable is glazed, only a small section of the channel is required at the ridge- this should line through with the underside and front of adjacent stub steels (duo pitch detail shown).

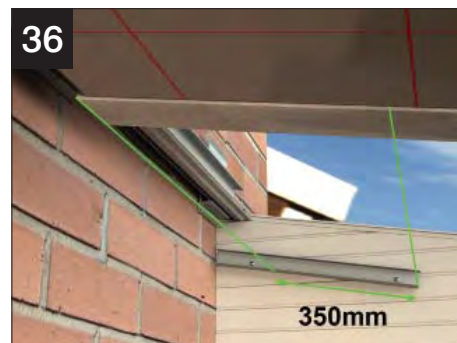

Mono-pitch detail shown- if adjacent steel is full length the offset distance from the top of the steel is 350mm.

APPENDIX 7 - ROOF VENT - GLAZED PANELS

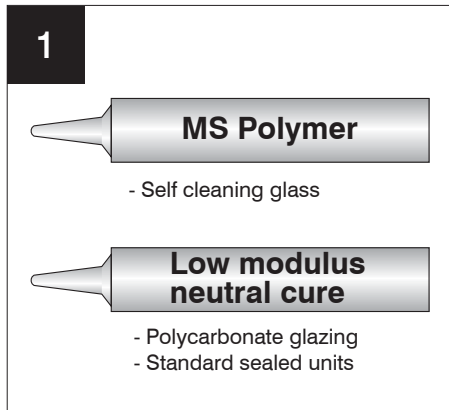

The vents are supplied unglazed – glazing wedges are cut to length.
Dispose of all packaging safely and in an environmentally friendly way.
Always use the correct sealant for the type of glazing material

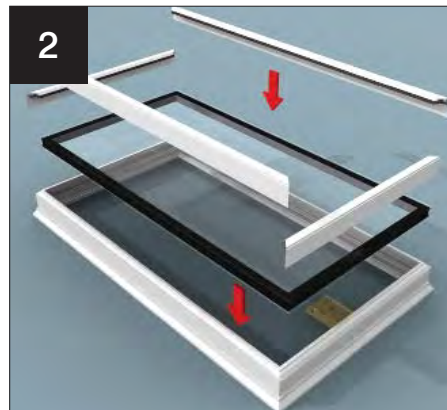

Remove vent 'lid' from the box and lay the correct way up on a protective clean surface. It may be easier to remove the winder mechanism. (See step 2a). Now fit glazing panel into place. Take the top and bottom un-mitre beads, run a bead of the appropriate sealant along both ends of the bead and clip into place. Now fit the mitre cut beads in the same manner.



Remove the winder mechanism if pre-fitted – pull the spring loaded clip to release.



Now, invert the vent 'lid' (protecting the painted finish). Fit the wedge gasket, starting next to the manual vent bracket.

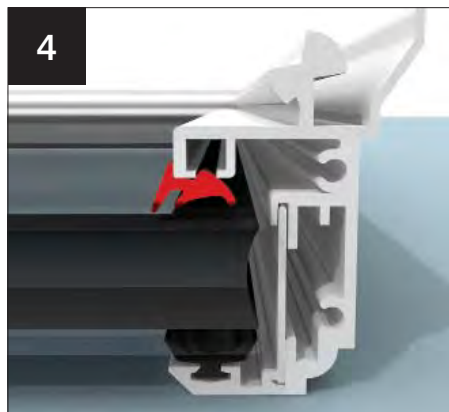

Insert gasket under vent under aluminium lip and work round the lid, cutting and notching in each corner and up to the vent bracket.

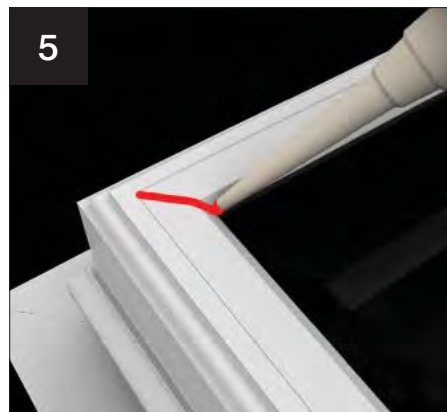

Turn back over and seal where the beads overlap. The lid is now ready.

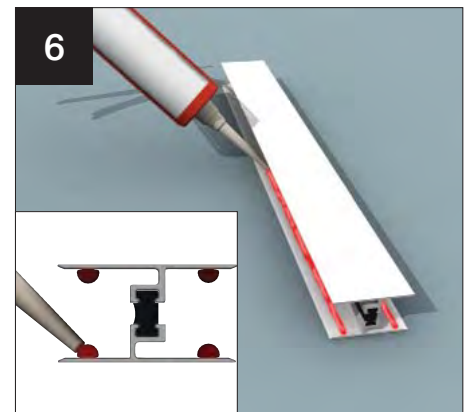

Now is the time to glaze the vent body into the roof. The vent is glazed in using two H sections at top and bottom. Prepare the upper H section using appropriate sealant in the four positions shown.

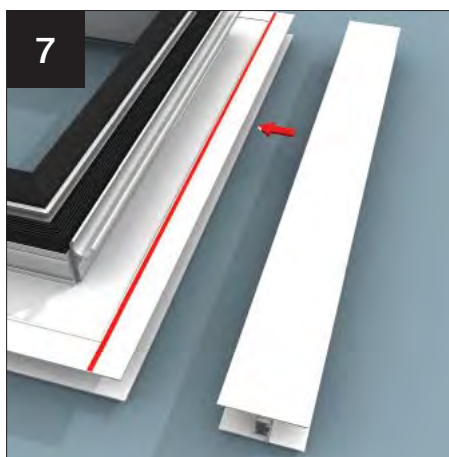

Prepare the lower H section using appropriate sealant in the four positions shown in step 6.



Apply bead of appropriate sealant to top edge of vent body and then slide vent body into upper H section. Repeat process for lower glazing panel H section and insert into trailing edge of vent body. Ensure glazing/vent body are central between the two glazing bars.



Using appropriate sealant (low modulus neutral cure for polycarbonate and MS Polymer for self cleaning glass), run beads along top and bottom edges of both H sections.

APPENDIX 7 - ROOF VENT - GLAZED PANELS



Now lift the pre-glazed lid into position and centralise –this may require two persons to safely handle it.

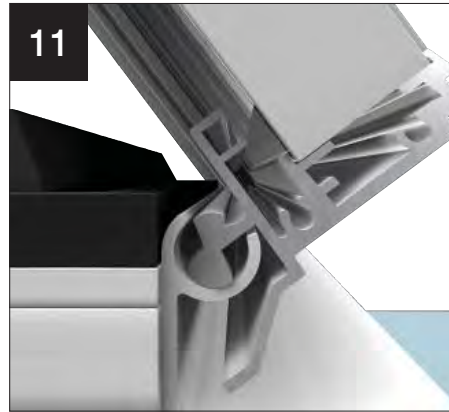

Lid knuckle will only engage with vent body hinge when lid is greater than 50 degrees. Once engaged, close lid.

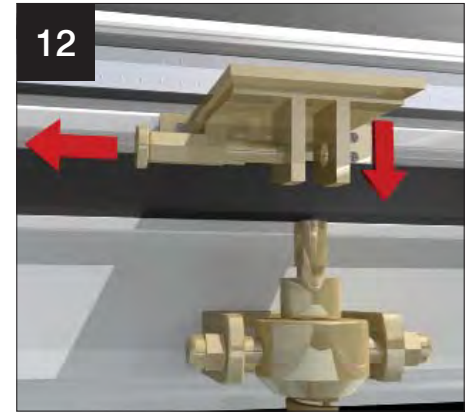

Now is the time to fit the spindle (if manually controlled). Remove spring pin if not already done. Attach spindle to lid. Now unscrew bolts in vent body, unwind spindle to correct height to align with bracket. Screw in bolts to secure spindle in position and re-attach spring pin.

VENT MOTOR

- CABLES CAN BE HIDDEN IN CLADDINGS & PRIOR TO ROOF BUILD

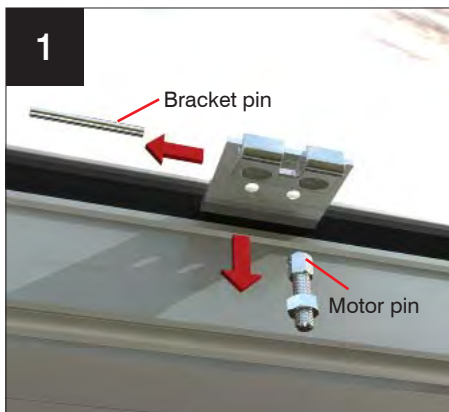

Pull out bracket pin to allow the vent motor pin to drop free.

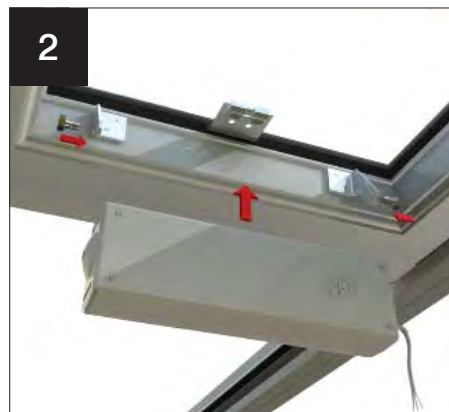

Offer up the motor to the brackets on vent body and secure.

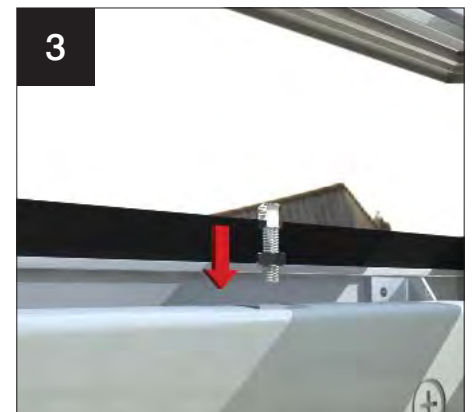

Screw motor pin into the top edge of the motor – adjust its height to fit with lid bracket.

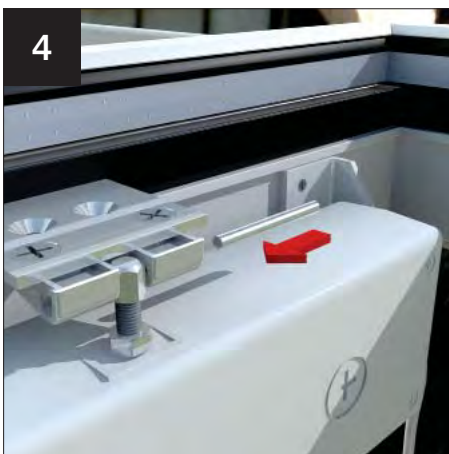

Refit lid bracket pin. Thread the motor pin nut downwards to secure.

NOTE If using a rain sensor, it can be mounted anywhere on the roof but in an exposed area. Ensure water cannot run down the cable and into the sensor. Thermostat and rain sensor electric pack comes complete with its own instructions.

APPENDIX 8 - MUNTIN (GLASS JOINTER)

Aluminium Muntin Bar



Take the muntin bar profile (top and bottom section) that matches its corresponding sealed unit. Take the lower PVCu section and allow it to span between the two adjacent glazing bars. Lower into position the up slope sealed unit. NOTE: MUNTIN SHOULD BE SAME WIDTH AS UNIT.

Now take the upper aluminium section and lay it face down onto a smooth clean surface to protect its painted finish. Using the relevant sealant (MS Polymer sealant such as Rotabond 2000 must be used on self cleaning glass), apply a generous bead to each side.

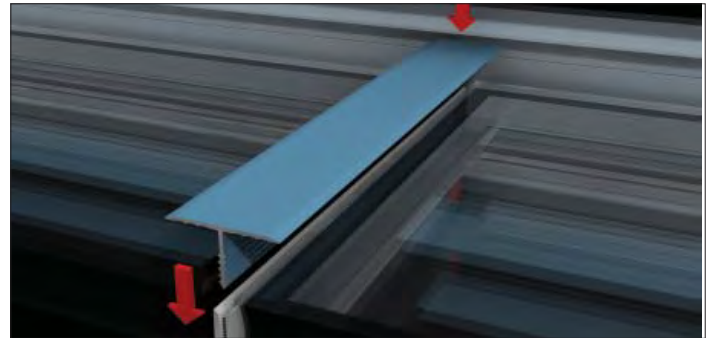

Now lift the sealed unit that goes on the lower slope into position, turn the upper profile over, place it into position and tap down the profile using a non marking plastic mallet. Wipe clean any sealant from the unit face. NOTE: WE RECOMMEND A SECOND PERSON TO SUPPORT THE MUNTIN FROM THE UNDERSIDE WHEN TAPPING DOWN.

Now, tap the glazing top cap into position, which will 'trap' the muntin profiles.

Aluminium Glazing End Closure



Take the painted profile and protect its surface. Apply a bead of relevant sealant (MS polymer on self cleaning glass). Slide into position on sealed unit, wipe clean any sealant from surface of glass.

Removing The Glazing Bar Top Caps



Slide the end cap up and off the fixing block and unscrew the fixing at the end of the glazing bar and then lift with force to 'pop' capping off (reverse steps 50-52 on p20). There are 2 methods to release the top cap. Slide the glazing bar top cap down or alternatively, insert a broad flat head screw driver into the gap above the aluminium barbs and 'pop' top cap and using hands lift capping free of clips. One or more clips - LVCC001 - may be damaged during the process, spares are sent with each roof.

APPENDIX 9 - ALTERNATIVE RIDGE BOARD DETAIL



It may be desirable to create a 'box' detail under the ridge board to facilitate the inclusion of downlights etc. Note: Ultraframe does not supply an off the shelf solution for this detail.

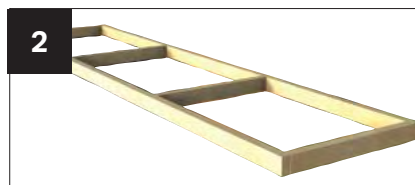

Construct a timber framework with cross members positioned where appropriate for adequate fixing of your chosen cladding (plasterboard, plywood etc.)



Fix the timber into position using screws of sufficient length to pass through ridge board and into the struts, as shown.

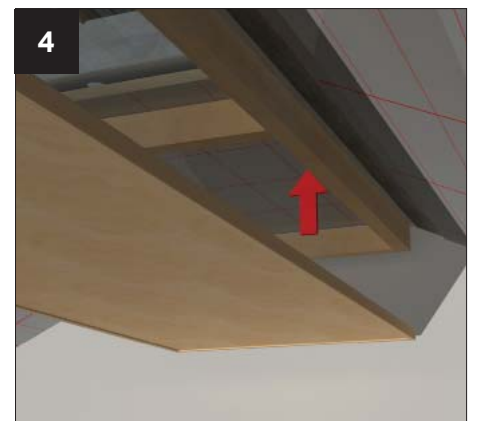

Clad the box with the preferred material (plasterboard, plywood etc.) and finish with a decorative timber edge moulding

APPENDIX 10 - GLAZING BAR TOP CAP REMOVAL



NOTE: If present - it may be necessary to remove the top section of the cornice to obtain proper access for top cap removal. Remove the screw attaching the top cap to the bar. Grip the top cap firmly and pull down the bar by approximately 150mm.



On long bars, friction may prevent the cap from sliding down the bar. In this case, push a long screw driver under the top cap and pull upwards to release the lower section.



Using 2 hands, pull the top cap upwards sharply to disengage the top cap clips and remove.

NOTE: top cap clips are likely to be damaged when removing caps – these will need to be replaced.

CLEANING AND MAINTENANCE

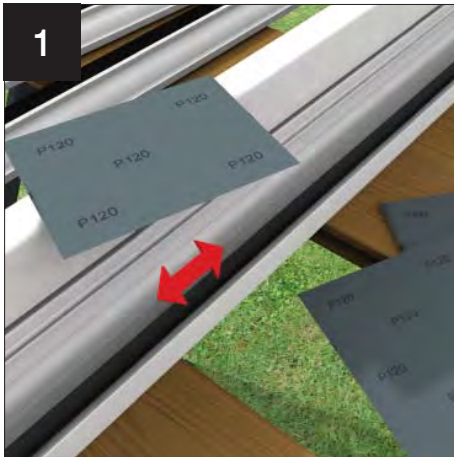

If surface damage is encountered, use 120-360 grit paper to prepare the surface. Wipe clean with white spirit.



Ensure the surface is dry – apply a thin primer coat using a fine brush.



Finally, apply an air drying top coat with a fine brush.

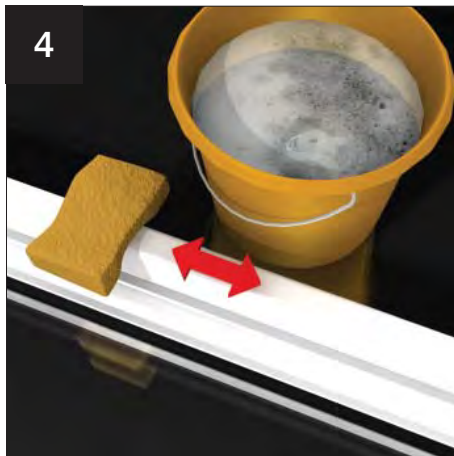

General cleaning can be undertaken by a wash with warm soapy water.

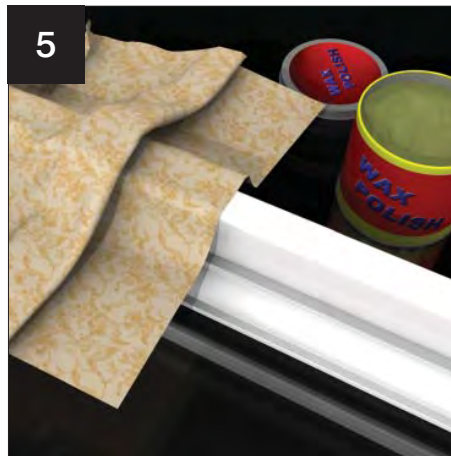

For added protection, a wax polish can be applied up to twice per year – follow the polish manufacturer's instructions carefully.

PLEASE PASS TO HOMEOWNER

It should be noted that polyester powder coatings are not maintenance free – the extent of cleaning depends upon the local environment and on the attitude of the building owner. Think cars here... if the building owner wants a finish like that, more regular cleaning is needed. All paints will 'chalk' to some extent and there will be a reduction in gloss level over time – this can be restored.